

LECTURE NOTE
REFRIGERATION AND AIR CONDITIONING
TH5.

HADU BANDHU DAKUA
(LECTURER IN MECHANICAL ENGG. DEPT.)
UMA CHARAN PATNAIK ENGG. SCHOOL , BERHAMPUR

Th5. REFRIGERATION AND AIR CONDITIONING

1.0 AIR REFRIGERATION CYCLE

1.1 Definition of Refrigeration:

The term refrigeration refers to the process of removing heat from an enclosed space or substance for the purpose of lowering the temperature.

Units of Refrigeration:

The practical unit of refrigeration is expressed in terms of tonne of refrigeration.

A tonne of refrigeration effect produced by the uniform melting of one tonne (1000 kg) of ice from and at 0°C in 24 hours. Since the latent heat of ice is 335 KJ/kg.

Therefore

$$1\text{TR} = 1000 \times 335 \text{ JH ub 24 hours}$$

$$\frac{1000 \times 335}{24 \times 60} = 232.6 \text{ KJ/min}$$

In actual practice, one tonne of refrigeration is taken as equivalent to 210KJ/min or 3.5KW (i.e. 3.5 KJ/S).

1.2 Definition of COP :

The **coefficient of performance, COP**, of a **refrigerator** is defined as the heat removed from the cold reservoir Q_{cold} (i.e., inside a **refrigerator**) divided by the work W done to remove the heat (i.e., the work done by the compressor). The COP strongly depends on outside temperature and required indoor temperature.

Refrigerating effect(R.E):

The heat absorbed or extracted by the liquid vapour refrigerant during evaporation per kg of refrigerant is called Refrigerating Effect.

1.3 Principle of working of Open air system of refrigeration:

In an open refrigeration system, the air is directly passed over the space is to be cooled, and allowed to circulate through the cooler. The pressure of open refrigeration cycle is limited to the atmospheric pressure. A simple diagram of the open-air Refrigeration system is given below.

Principle of working of closed air system of refrigeration:

In closed or dense air refrigeration cycle, air refrigerant is contained within pipes and component part of the system at all time. The circulated air does not have to direct contact with the space to be cooled. The air is used to cool another fluid (brine), and this fluid is circulated into the space to be cooled. So the disadvantages listed in open air refrigeration can be eliminated. The advantages of closed air refrigeration system are

1.3.1 COP of Bel-Coleman cycle:

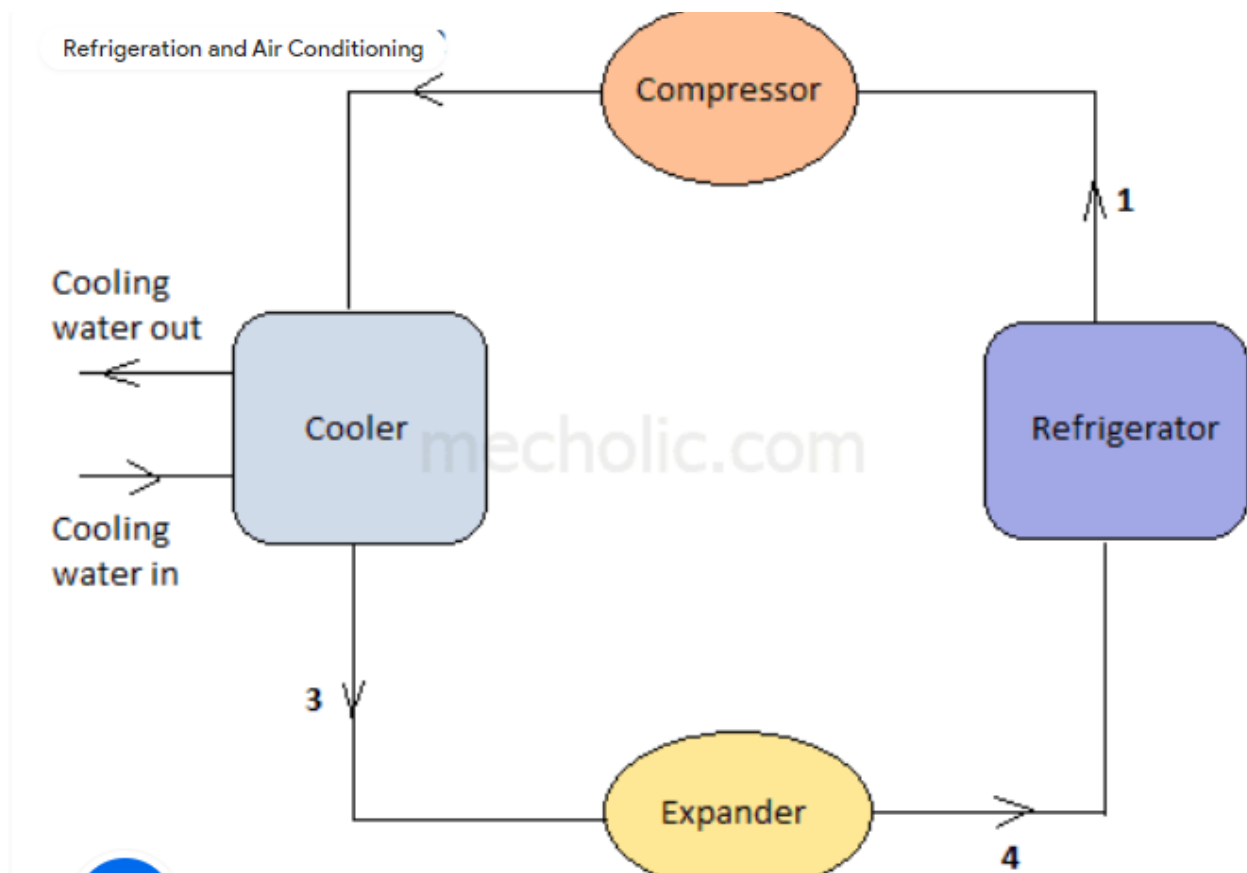

Fig shows a schematic diagram of Bell-Coleman refrigerator (reverse Brayton or joule cycle). This refrigeration system components consists of a [compressor](#), cooler, Expander, and refrigerator. In this process, heat absorption and rejection follows at the constant pressure; the compression and expansion of process are isentropic.

Different process in Bell-Coleman refrigeration:

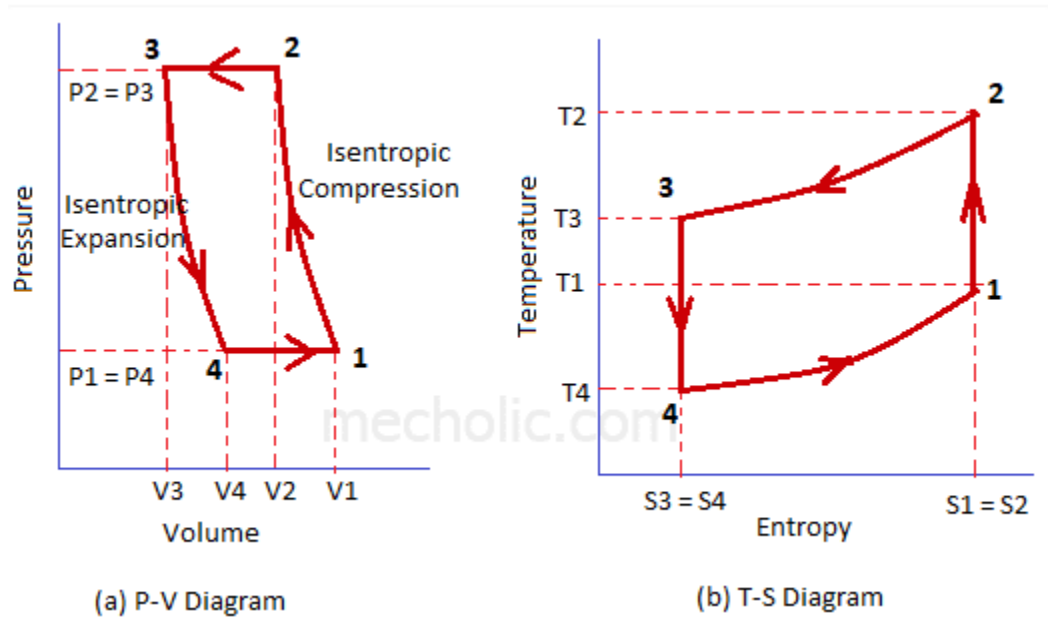

Fig show P-V and T-S diagram of bell coleman refrigerator. Here P_1, V_1, T_1, S_1 represents the pressure, volume, temperature, entropy of air respectively at point 1. And so on. It represents the corresponding condition of air when it passed through the component.

1-2: Isentropic Compression

The Air drawn from refrigerator to air compressor cylinder where it compressed isentropically (constant entropy). No heat transfer by the air. During compression, the volume decreases while the pressure and temperature of air increases.

2-3: Constant pressure cooling process.

The warm compressed air is then passed through cooler, where it cooled down at constant pressure. The heat rejected per kg of air during this process is equal to $q_{2-3} = C_p(T_2 - T_3)$

3-4: isentropic expansion

No heat transfer takes place. The air expands isentropically in expander cylinder. During expansion, the volume increases, Pressure P_3 reduces to P_4 . ($P_4 =$ atmospheric pressure). Temperature also falls during expansion from $T_3 - T_4$.

4-1: Constant pressure expansion

Heat transfer from the refrigerator to air. The temperature increases from T_4 to T_1 . Volume increases to V_4 due to heat transfer. Heat absorbed by air per kg during this process is equal to $q_{4-1} = C_p(T_1 - T_4)$

Equation of Coefficient of performance (COP) of Bell Coleman cycle:

Heat absorbed during cycle per kg of air $q_{4-1} = C_p(T_1 - T_4)$

Heat rejected during cycle per kg of air $q_{2-3} = C_p(T_2 - T_3)$

Then the work done per kg of air during the cycle is = Heat rejected – Heat absorbed
= $C_p(T_2 - T_3) - C_p(T_1 - T_4)$

Coefficient of performance;

$$\begin{aligned} \text{C. O. P.} &= \frac{\text{Heat absorbed}}{\text{Work done}} = \frac{C_p(T_1 - T_4)}{C_p(T_2 - T_3) - C_p(T_1 - T_4)} \\ &= \frac{(T_1 - T_4)}{(T_2 - T_3) - (T_1 - T_4)} \\ \text{C. O. P.} &= \frac{T_4\left(\frac{T_1}{T_4} - 1\right)}{T_3\left(\frac{T_2}{T_3} - 1\right) - T_4\left(\frac{T_1}{T_4} - 1\right)} \quad \text{(i)} \end{aligned}$$

For isentropic compression process 1-2

$$\frac{T_2}{T_1} = \left(\frac{P_2}{P_1}\right)^{\frac{\gamma-1}{\gamma}} \quad \text{(ii)}$$

For isentropic expansion process 3-4

$$\frac{T_3}{T_4} = \left(\frac{P_3}{P_4}\right)^{\frac{\gamma-1}{\gamma}} \quad \text{(iii)}$$

Since, $P_2 = P_3$ and $P_1 = P_4$, therefore from equation (ii) and (iii)

$$\frac{T_2}{T_1} = \frac{T_3}{T_4} \quad \text{or} \quad \frac{T_2}{T_3} = \frac{T_1}{T_4} \quad \text{(iv)}$$

Substitute equation (iv) in (i)

$$C.O.P. = \frac{T_4}{T_3 - T_4} = \frac{1}{\frac{T_3}{T_4} - 1}$$

$$= \frac{1}{\left(\frac{P_3}{P_4}\right)^{\frac{\gamma-1}{\gamma}} - 1} = \frac{1}{\left(\frac{P_2}{P_1}\right)^{\frac{\gamma-1}{\gamma}} - 1}$$

$$C.O.P. = \frac{1}{(r_p)^{\frac{\gamma-1}{\gamma}} - 1}$$

$$r_p = \text{Compression or Expansion ratio} = \frac{P_2}{P_1} = \frac{P_3}{P_4}$$

Questions for exercise/assignment:

Short questions

1. Define Tonne Of Refrigeration.
2. Define Refrigerating Effect.
3. Mention different process of Bel-coleman cycle.

Long questions

1. Derive the COP of Bel-Coleman Cycle.
2. Briefly explain working of Open air system of refrigeration.

References:

- <https://www.mecholic.com/2017/09/open-and-closed-type-of-refrigeration.html#:~:text=In%20an%20open%20refrigeration%20system,Refrigeration%20system%20is%20given%20below.>
- <https://www.mecholic.com/2017/12/bell-coleman-refrigeration-cycle.html>

2.0 SIMPLE VAPOUR COMPRESSION REFRIGERATION SYSTEM

2.1 Schematic Diagram of simple vapours compression refrigeration system:

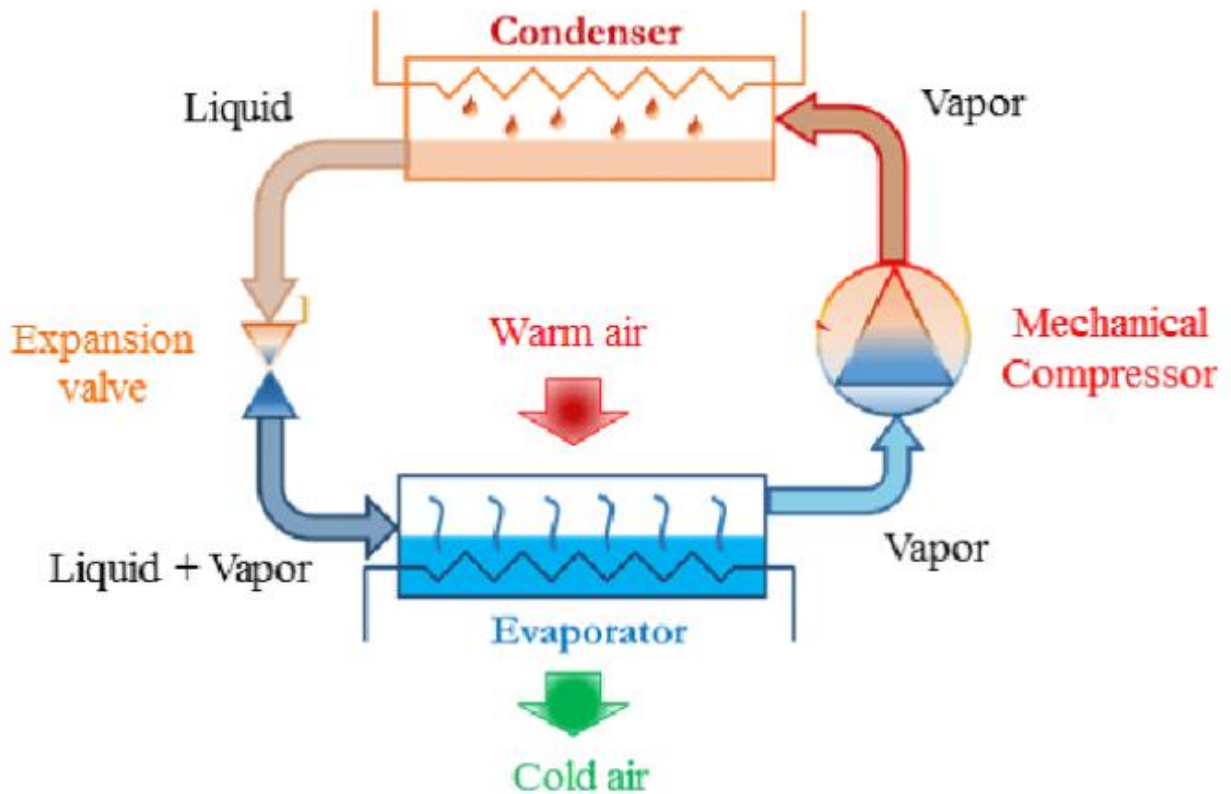

2.2 Types of vapour compression refrigeration system are

2.2.1 Cycle with dry saturated vapors after compression.

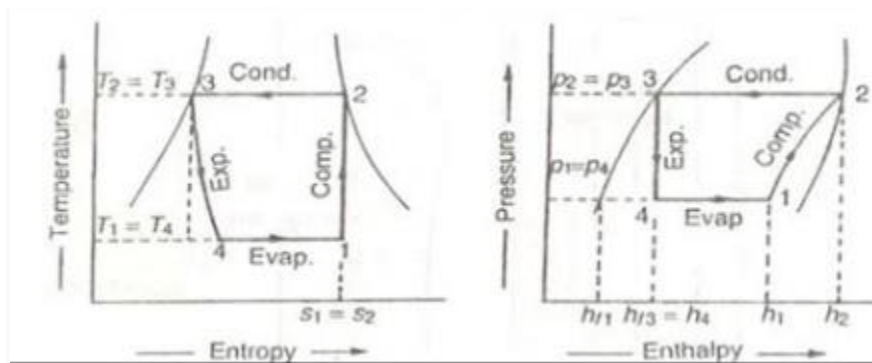

1. Compression process: The vapour refrigerant at low pressure p_1 and temperature T_1 is compressed isentropically to dry saturated vapour as shown by the vertical line 1-2 on T-s diagram and by the curve 1-2 on p-h diagram. The pressure and temperature rises from p_1 to p_2 and T_1 to T_2 respectively.

The Work done during isentropic compression per kg of refrigerant is given by: $w = h_2 - h_1$.

Where h_1 = Enthalpy of vapour refrigerant at temperature T_1 , i.e. at suction of the compressor, and h_2 = Enthalpy of the vapour refrigerant at temperature T_2 , is i.e. at discharge of the compressor.

2. Condensing process: The high pressure and temperature vapour refrigerant from the compressor is passed through the condenser where it is completely condensed at constant pressure p_2 and temperature T_2 , as shown by the horizontal line 2-3 on T-s and p-h diagrams. The vapour refrigerant is changed into liquid refrigerant. The refrigerant, while passing through the condenser, gives its latent heat to the surrounding condensing medium.

3. Expansion process: The liquid refrigerant at pressure $p_3 = p_2$ and temperature $T_3 = T_2$ is expanded by throttling process through the expansion valve to a low pressure $p_4 = p_1$ and temperature $T_4 = T_1$, as shown by the curve 3-4 on T-s diagram and by the vertical line 3-4 on p-h diagram. We have already discussed that some of the liquid refrigerant evaporates as it passes through the expansion valve; but the greater portion is vaporised in the evaporator. We know that during the throttling process, no heat is absorbed or rejected by the liquid refrigerant.

Notes:

(a) In case an expansion cylinder is used in place of throttle or expansion valve to expand the liquid refrigerant, then the refrigerant will expand isentropically as shown by dotted vertical line on T-s diagram. The isentropic expansion reduces the external work being expanded in running the compressor and increases the refrigerating effect. Thus, the net result of using the expansion cylinder is to increase the coefficient of performance.

Since the expansion cylinder system of expanding the liquid refrigerant is quite complicated and involves greater initial cost, therefore its use is not justified for small gain in cooling capacity. Moreover, the flow rate of the refrigerant can be controlled with throttle valve which is not possible in case of expansion cylinder which has a fixed cylinder volume.

(b) In modern domestic refrigerators, a capillary (small bore tube) is used in place of an expansion valve.

4. Vaporising process: The liquid-vapour mixture of the refrigerant at pressure $p_4 = p_1$ and temperature $T_4 = T_1$ is evaporated and changed into vapour refrigerant at constant pressure and temperature, as shown by the horizontal line 4-1 on T-s and p-h diagrams. During evaporation, the liquid-vapour refrigerant absorbs its latent heat of vaporisation from the medium (air, water or brine) which is to be cooled. This heat which is absorbed by the refrigerant is called refrigerating effect and it is briefly written as R_e . The process of vaporisation continues up to point 1 which is the starting point and thus the cycle is completed.

The refrigerating effect or the heat absorbed or extracted by the liquid-vapour refrigerant during evaporation per kg of refrigerant is given by:

$$R_E = h_1 - h_4 = h_1 - h_{f3}$$

Where h_{f3} is the Sensible heat at temperature T_3 , i.e. enthalpy of Liquid refrigerant leaving the condenser

It can be noticed from the cycle that the liquid-vapour refrigerant has extracted heat during evaporation and the work will be done by the compressor for isentropic compression of the high pressure and temperature vapour refrigerant.

$$\text{COP} = \frac{\text{Refrigerating effect}}{\text{Work Done}} = \frac{h_1 - h_4}{h_2 - h_1}$$

2.2.2 Cycle with wet vapors after compression.

A vapour compression cycle with *wet vapour after compression* is shown on T-s and p-h diagrams below. In this cycle, the enthalpy at point 2 is found out with the help of dryness fraction at this point. The dryness fraction at points 1 and 2 may be obtained by equating entropies at points 1 and 2.

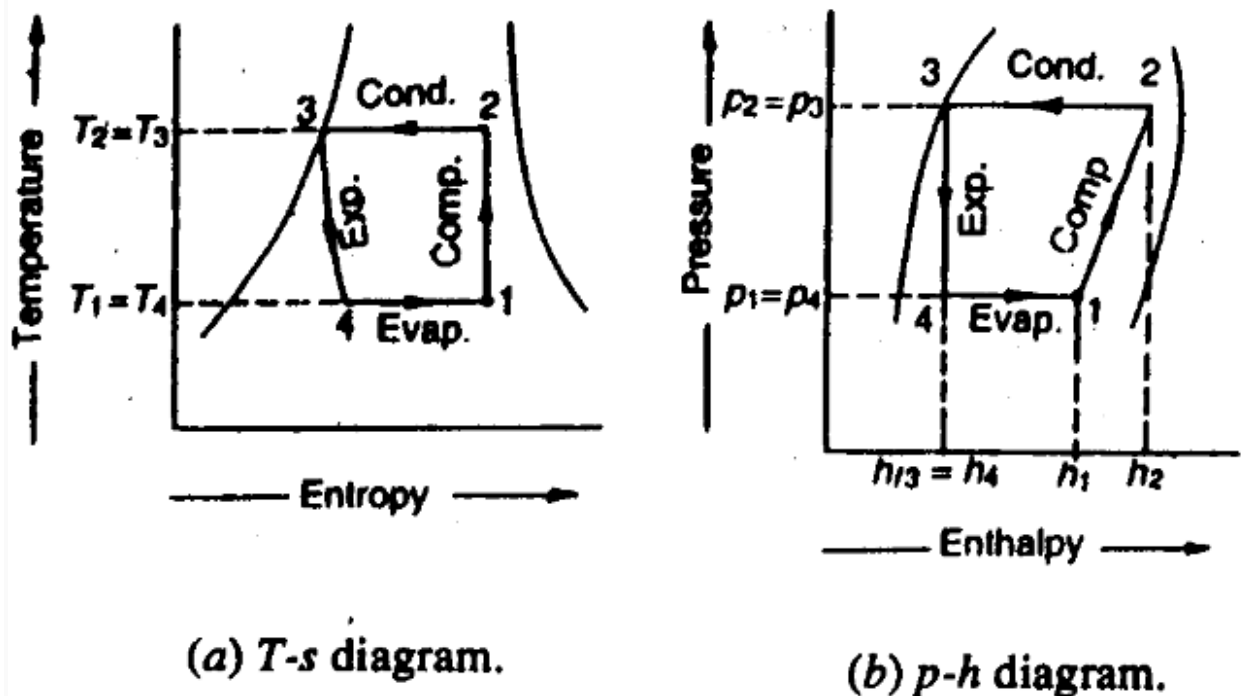

The remaining cycle is the same as discussed above, and the COP can be determined in the same manner.

In this cycle, enthalpy at state 2 is found with the help of dryness fraction at this point (2). The dryness fraction at points 1 and 2 may be obtained by equating entropies at state 1 and 2.

$$\text{C.O.P} = \frac{\text{refrigerating effect}}{\text{work done}} = \frac{h_1 - h_{f3}}{h_2 - h_1}$$

2.2.3 Cycle with superheated vapors after compression.

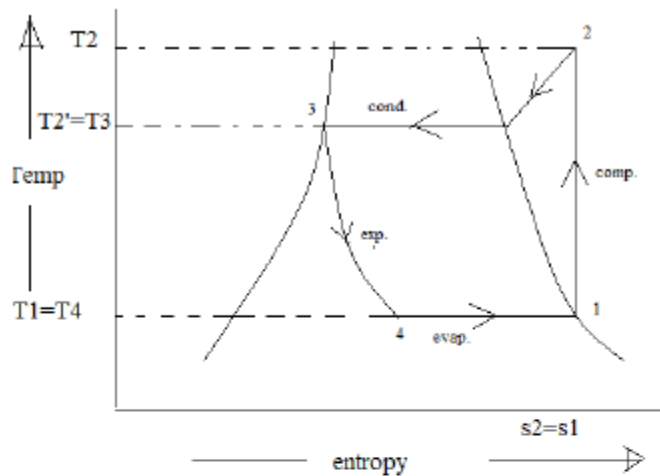

Fig.13 T-S diagram for Dry Vapour Compression Cycle

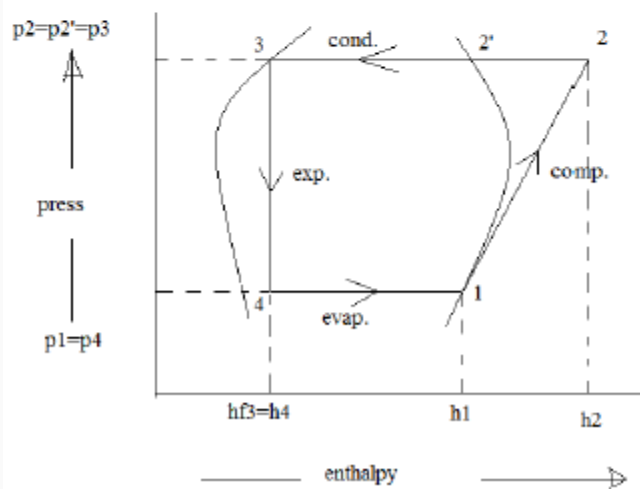

Fig. 14. P-h diagram for Dry Vapour Compression Cycle

In this cycle, the enthalpy at point 2 is four with the help of degree and superheat. The degree of superheat may be found by equating the entropies at point (1 & 2).

$$\text{C.O.P} = \frac{\text{refrigerating effect}}{\text{work done}} = \frac{h_1 - h_3}{h_2 - h_1}$$

2.2.4 Cycle with superheated vapors before compression.

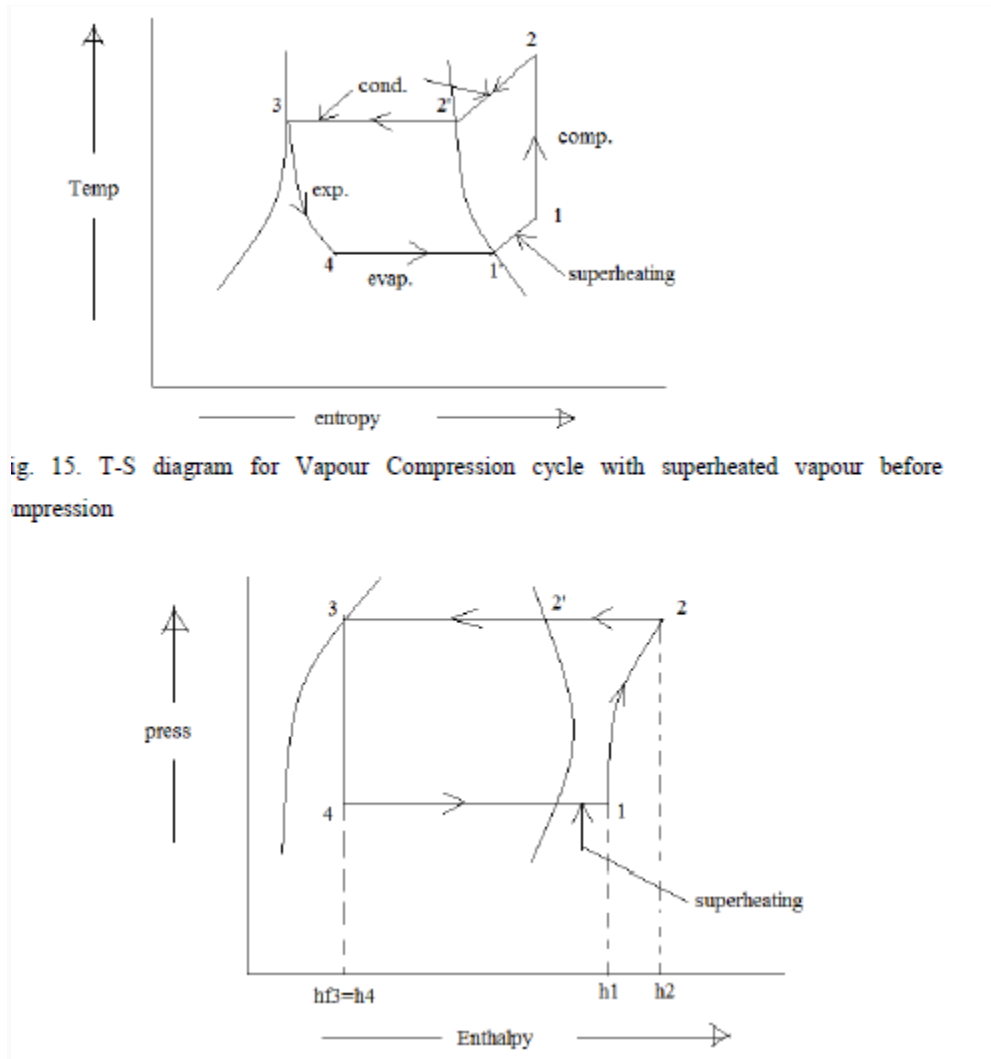
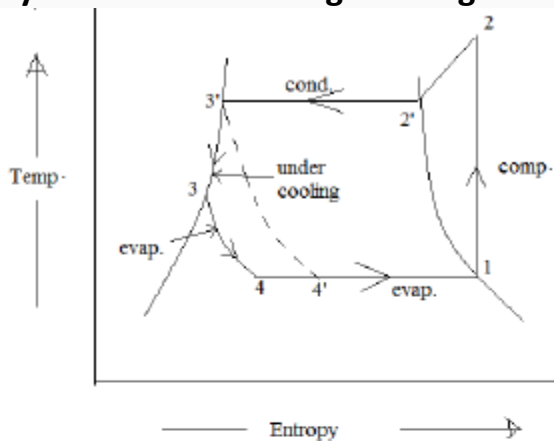

Fig. 16. P-h diagram for Vapour Compression cycle with superheated vapour before compression
In this cycle, the evaporation starts at state 4 and continues up to the point 1.

$$\text{C.O.P} = \frac{\text{Refrigerant effect}}{\text{workdone}} = \frac{h_1 - h_3}{h_2 - h_1}$$

2.2.5 Cycle with sub-cooling of refrigerant.



17. T-S diagram for Vapour Compression cycle with undercooling refrigerant.

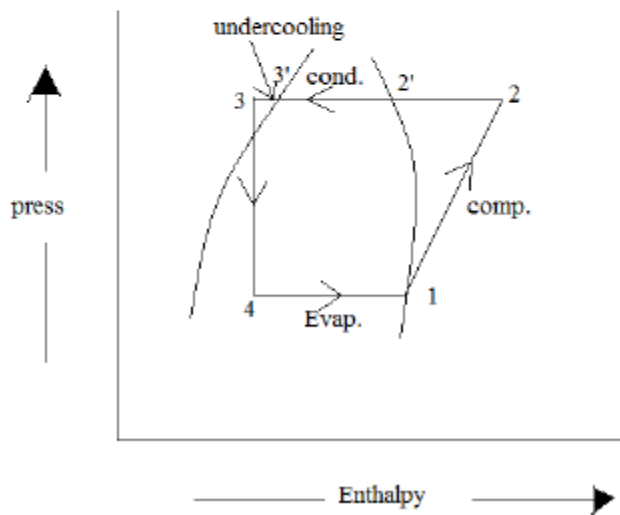

Fig. 18. P-h diagram for Vapour Compression cycle with undercooling refrigerant.

After condensation in process 2'-3', the refrigerant is cooled below the saturation temperature ($T_{3'}$) before expansion by throttling; such a process is called **undercooling** or **sub cooling** of the refrigerant and is generally done along the liquid line. The ultimate effect of undercooling is increase the value of coefficient of performance under the same set of conditions.

The process of undercooling is done by circulating more quantity of cooling water through the condenser; it is also achieved by employing a heat exchanger. In actual practice the refrigerant is superheated after compression and undercooled before throttling. The refrigerating effect is a little bit increased by adopting both the superheating and undercooling process as compared with a cycle without them.

In this case, the refrigerating effect or heat absorbed or extracted.

$$Re = h_1 - h_4$$

$$= h_1 - h_{f3}$$

$$\text{And work done, } W = h_2 - h_1$$

$$\text{But } h_{f3} = h_{f3'} - c_p \cdot \text{degree of undercooling}$$

Questions for exercise/assignment:

Short questions

1. Define Throttling with VCRS.
2. Draw TS and PH diagram of Cycle with sub-cooling of refrigerant.
3. Draw TS and PH diagram of Cycle with superheated vapors after compression.

Long questions

1. Derive the COP Cycle with dry saturated vapors after compression.
2. Derive the COP Cycle with superheated vapors before compression compression.

REFERENCES:

1. <https://www.ques10.com/p/38997/other-types-of-vapour-compression-cycles/>
2. <https://prog.lmu.edu.ng/colleges\CMS/document/books/MCE537%20-%20REFRIGERATION%20CYCLE.pdf>

3.0 VAPOUR ABSORPTION REFRIGERATION SYSTEM

3.1 Simple vapour absorption refrigeration system:

A Simple Vapor absorption system consists of evaporator, absorber, generator, condenser, expansion valve, pump & reducing valve. In this system ammonia is used as refrigerant and solution used is aqua ammonia. Strong solution of aqua ammonia contains as much as ammonia as it can and weak solution contains less ammonia. The compressor of vapor compressor system is replaced by an absorber, generator, reducing valve and pump. The heat flow in the system at generator, and work is supplied to pump. Ammonia vapors coming out of evaporator are drawn in absorber. The weak solution containing very little ammonia is spread in absorber. The weak solution absorbs ammonia and gets converted into strong solution. This strong solution from absorber is pumped into generator. The addition of heat liberates ammonia vapor and solution gets converted into weak solution. The released vapor is passed to condenser and weak solution to absorber through a reducing valve. Thus, the function of a compressor is done by absorber, a generator, pump and reducing valve. The simple vapor compressor system is used where there is scarcity of electricity and it is very useful at partial and full load.

Working of Vapour Absorption Refrigeration System:

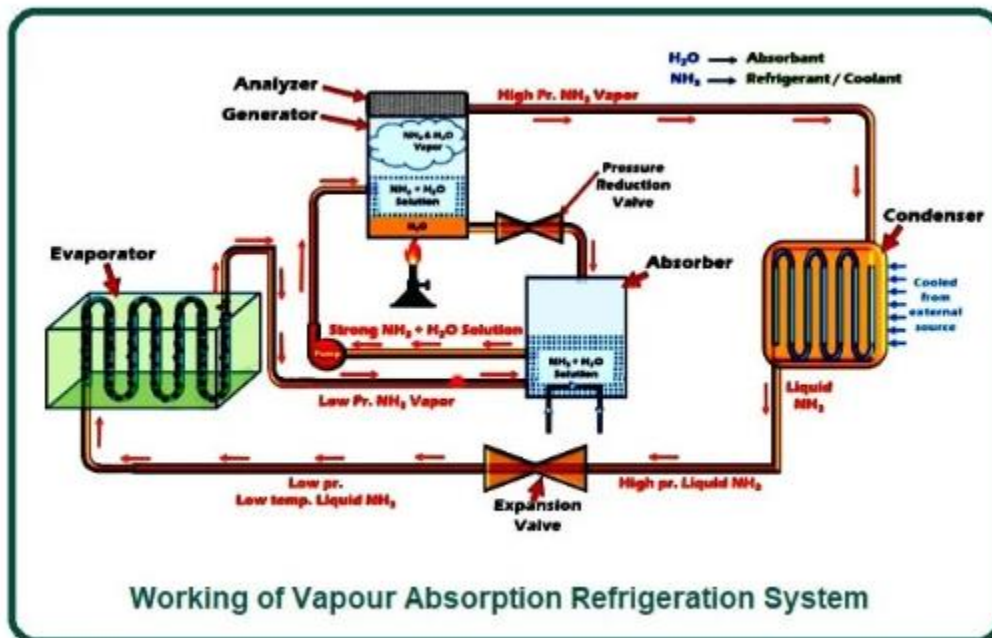

The next component and analyzer send water particles back to the generator through this pipe for further processing. With this generator, the diluted solution of water and ammonia residues deposited here will be sent back to the absorber again. The very cold liquid will exit the ammonia expansion valve that enters the evaporator coil through the connected pipe. The main cooling is always in the evaporator.

When liquid ammonia enters the evaporator coil, it will absorb all the heat present on the surface of the evaporator coil by absorbing all the heat from the area around the evaporative coil. The cooled liquid ammonia will convert to ammonia vapor inside these coils, and the surrounding surface of the evaporator will be cooled by losing heat to the liquid; thus, a cooling effect or refrigeration effect has occurred inside the evaporator. It will then release the low-pressure ammonia vapor evaporator and enter the absorber through the connecting pipe.

The absorber already has a weak solution of ammonia and the water inside it, and when it enters the low-pressure ammonia vapor absorber, the water present in the weak solution of this absorber will start absorbing this ammonia vapor, and a weak solution will gradually transform into a strong one— Ammonia-water solution.

The more ammonia vapor from the evaporator is absorbed by the water of this weaker solution, the stronger the solution will form, but when the water absorbs the ammonia vapor, it also releases it from heat. When the water absorbs the incoming ammonia vapor, it will produce heat that will increase the temperature of the solution, & when the solution is heated, the ability of the water to absorb the ammonia gradually decreases.

To keep the slurry temperature at an optimum level, cold water is supplied through this pipe so that this cold water keeps the heat away from the slurry, and thus the water gains the ability to absorb the incoming ammonia vapor continuously.

There is a pump next to the absorber; now that power is provided, this pump starts working. A strong solution of ammonia & water will be pumped from the absorber to the generator using this pump.

An Auxiliary generator or external heat is provided to this generator using steam or hot water or any heater, gas burner. So when the ammonia and water solution reaches the generator and heat is applied to the slurry from an external source, the water from the ammonia-water solution both turn into vapor inside this generator.

In fact, ammonia turns into vapor faster than water, and water completely turns into vapor. But eventually, both ammonia & water will turn into vapor upon providing heat. Now here we also have analyzers on top of the generator. Only ammonia is allowed to pass when ammonia and water vapor try to pass through this analyzer.

The analyzer continuously condenses the water vapor & sends water back to the generator. This is because if water vapor enters the system, it may reduce the efficiency of the refrigeration system, or if a large amount of water vapor enters the system, the system may be damaged; Thus, the analyte separates the water particles from the ammonia vapor and only allows the ammonia to pass through the pressure reducing valve.

Therefore the high pressure, high-temperature pure ammonia vapor coming out of the generator will now enter the condenser through this connected pipe. We have a condenser; When high pressure, high-

temperature ammonia Vapour enters the cold condenser, the condenser absorbs heat from the ammonia vapor and converts it completely into a liquid

This condenser can be either water-cooled or air-cooled. This will release the latent heat of the Vapour coming into the condenser, and thus condensation continues.

Now we have an expansion valve. After condensation, the liquid ammonia will release the condenser and pass-through this expansion valve. Now inside this expansion valve, the high-pressure liquid ammonia coming from the condenser will be expanded. We know that when the expansion occurs, the pressure between the molecules decreases significantly.

Thus as the temperature falls, this high-pressure liquid ammonia will be expanded into low-pressure, low-temperature liquid ammonia; Thus, we exit the very cold low-temperature liquid ammonia expansion valve.

After that, this liquid ammonia will be passed through the connection pipe to the evaporator, absorbing all the heat from the area around the evaporator coil, the cooled cold liquid ammonia will again turn into low-pressure ammonia Vapour inside the coil, And the area around the evaporator will be cooled by losing heat to this liquid.

This low-pressure ammonia Vapour will then release the evaporator and enter the absorber through this connecting pipe. This entire cycle will be repeated again and again. Therefore, refrigeration will occur continuously in the evaporation zone.

Components in Vapour Absorption Refrigeration System:

1. Evaporator

The main function of the evaporators is to provide cooling to the area with which it is in contact. The cooled liquid will enter inside this evaporator and receive heat from the evaporator, and be converted into vapor. This Vapour will be at low pressure. With this evaporator, the ammonia Vapour comes out under low pressure and will go towards the absorber.

2. Absorbers

Absorbers are used to absorb refrigerants. In the absorber, there will be a weak solution of water and ammonia. When the ammonia Vapour from the evaporator reaches the absorber, the water present in the absorber will absorb it. As the water absorbs the ammonia, a strong ammonia solution and water will begin to form.

When the water absorbs ammonia, the water will liberate from the heat, and the absorptive capacity of the water will be reduced. So, cold water is supplied to the absorber so that the absorptive capacity is high so that it is continuously absent of ammonia vapor.

3. Pump

The pump will pump a strong solution of ammonia and water from the absorber to the generator.

4. Generator

Ammonia and water solutions are used inside this system. Ammonia is used as a refrigerant, & water is used as an absorbent.

A solution of these two is formed because water has a strong affinity for ammonia. Water plus ammonia solutions are present inside the absorber.

The generator is provided with auxiliary heat from outside. This auxiliary can be used to provide heat,

steam or hot water, or any type of heater. Heat is provided so that the solution of ammonia and water is converted into vapor.

5. Analyzer

The analyzers are placed on top of the generator. Ammonia will convert to Vapour before water, but some water particles convert to Vapour along with ammonia. This analyzer is used to separate water particles from ammonia vapor.

If water particles move past the generator, it will reduce the efficiency of the entire system. If the water particles move in large quantities, it can also damage the system.

So the analyzer condenses the water's particles, but the ammonia Vapour will pass through the analyzer and go further into the system. Some ammonia will also condense in the vapor analyzer, but most of the ammonia will pass through the Vapour analyzer.

6. Pressure-Reducing Valve

After the ammonia Vapour passes through the analyzers, the weak solution present in the generators will pass through the pressure reducing valve and reach the absorber again.

7. Condenser

Condensers are used to convert ammonia Vapour into the liquid phase. These condensers can be either water-cooled or air-cooled.

8. Expansion Valve

Its main functions are to convert the liquid to cold liquid and pass it to the evaporator.

At the expansion valve, the ammonia will come from the liquid condenser, and the temperature and pressure of this liquid ammonia will decrease, and this ammonia will become the temperature of the liquid-cooled liquid ammonia, whose temperature will be much lower.

3.2 Practical vapour absorption refrigeration system:

Construction:

- The vapour absorption system consists of a condenser, an expansion valve and an evaporator.
- They perform the same as they do in vapour compression method.
- In addition to these, this system has an absorber, a heat exchanger, an analyser and a rectifier.

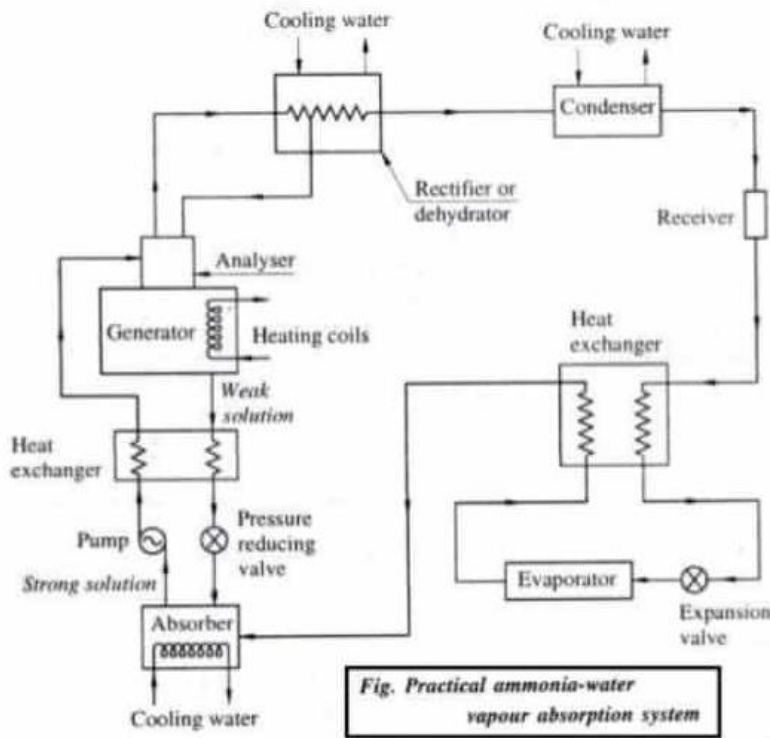

practical ammonia -water vapour absorption system

Working:

1. Dry ammonia vapour at low pressure passes in to the absorber from the evaporator.
2. In the absorber the dry ammonia vapour is dissolved in cold water and strong solution of ammonia is formed.
3. Heat evolved during the absorption of ammonia is removed by circulating cold water through the coils kept in the absorber.
4. The highly concentrated ammonia (known as Aqua Ammonia) is then pumped by a pump to generator through a heat exchanger.
5. In the heat exchanger the strong ammonia solution is heated by the hot weak solution returning from the generator to the absorber.
6. In the generator the warm solution is further heated by steam coils, gas or electricity and the ammonia vapour is driven out of solution.
7. The boiling point of ammonia is less than that of water.
8. Hence the vapours leaving the generator are mainly of ammonia.
9. The weak ammonia solution is left in the generator is called weak aqua.
10. This weak solution is returned to the absorber through the heat exchanger.
11. Ammonia vapours leaving the generator may contain some water vapour.
12. If this water vapour is allowed to the condenser and expansion valve, it may freeze resulting in choked flow.
13. Analyser and rectifiers are incorporated in the system before condenser.
14. The ammonia vapour from the generator passes through a series of trays in the analyser and ammonia is separated from water vapour.
15. The separated water vapour returned to generator.
16. Then the ammonia vapour passes through a rectifier.

17. The rectifier resembles a condenser and water vapour still present in ammonia vapour condenses and the condensate is returned to analyser.
18. The virtually pure ammonia vapour then passes through the condenser.
19. The latent heat of ammonia vapour is rejected to the cooling water circulated through the condenser and the ammonia vapour is condensed to liquid ammonia.
20. The high pressure liquid ammonia is throttled by an expansion valve or throttle valve.
21. This reduces the high temperature of the liquid ammonia to a low value and liquid ammonia partly evaporates.
22. Then this is led to the evaporator.
23. In the evaporator the liquid fully vaporizes.
24. The latent heat of evaporation is obtained from the brine or other body which is being cooled.
25. The low pressure ammonia vapour leaving the evaporator again enters the absorber and the cycle is completed.
26. This cycle is repeated again to provide the refrigerating effect.

3.3 COP of ideal vapour absorption refrigeration system:

If,

The heat supplied to the generator = Q_G

The heat rejected by the condenser to the atmosphere = Q_C

The heat absorbed by the refrigerant in the evaporator = Q_E

Then, from energy balance concept

$$Q_C = Q_G + Q_E$$

If, T_G = Temperature at which heat given to the generator

T_C = Temperature at which heat is discharged to the atmosphere from condenser

T_E = Temperature at which heat is absorbed in the evaporator

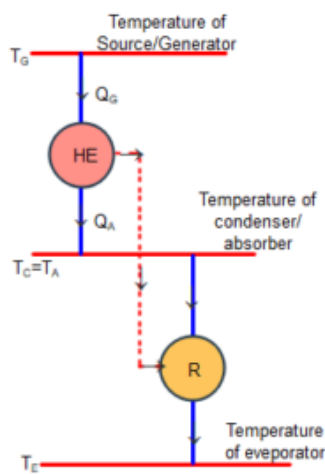

The vapour absorption system can be considered as a perfectly reversible system, therefore initial entropy of the system equal to the entropy of the system after the change in condition.

$$\text{So, } \frac{Q_G}{T_G} + \frac{Q_E}{T_E} = \frac{Q_c}{T_c}$$

$$= \frac{Q_G + Q_E}{T_C}$$

$$\text{Or, } \frac{Q_G}{T_G} - \frac{Q_G}{T_C} = \frac{Q_E}{T_C} - \frac{Q_E}{T_E}$$

$$\text{Or, } Q_G \left(\frac{T_C - T_G}{T_C T_G} \right) = Q_E \left(\frac{T_E - T_C}{T_C T_E} \right)$$

$$\text{Or, } Q_G = Q_E \left(\frac{T_E - T_C}{T_C T_E} \right) \left(\frac{T_G T_C}{T_C - T_G} \right)$$

$$\text{Or, } Q_G = Q_E \left(\frac{T_C - T_E}{T_C T_E} \right) \left(\frac{T_G T_C}{T_G - T_C} \right)$$

$$\text{Or, } Q_G = Q_E \left(\frac{T_c - T_E}{T_E} \right) \left(\frac{T_G}{T_G - T_c} \right)$$

Maximum COP of the system is expressed by

$$(COP)_{max} = \frac{Q_E}{Q_G}$$

$$= \frac{Q_E}{Q_E \left(\frac{T_c - T_E}{T_E} \right) \left(\frac{T_G}{T_G - T_c} \right)}$$

The expression $\frac{T_E}{T_C - T_E}$ is the COP of Carnot refrigeration working between T_E & T_C

The expression $\frac{T_G - T_C}{T_G}$ is the efficiency of Carnot heat engine working between T_G & T_C

So, the maximum COP of vapour absorption refrigeration may be written as

$$(COP)_{max} = (COP)_{carnot} \times \eta_{carnot}$$

Questions for exercise/assignment:

Short questions

1. Define Function of analyser.
2. Mention functions of heat exchanger with VARS..

Long questions

3. Derive the COP of ideal vapour absorption system.
4. In a vapor absorption refrigeration system, heating cooling and refrigeration take place at a temperatures of 100°C, 20°C and -5°C respectively. Find the maximum C.O.P of the system.

REFERENCES:

- <https://mechanicaljungle.com/working-of-vapour-absorption-refrigeration-system/>
- <https://academylocus.com/cop-of-an-ideal-vapour-absorption-refrigeration-system/>

4. REFRIGERATION EQUIPMENTS

4.0 REFRIGERANT COMPRESSORS:

4.1.0 Principle of working and constructional details of reciprocating compressor:

Reciprocating compressor also known as a piston compressor is a [positive displacement](#) device. It is one of the most widely used types of compressor in which gas is compressed by reciprocating motion of a piston. It handles low mass of gas but high pressure ratio. During the operation of reciprocating compression, it takes a large amount of gas from the suction line, it is then get compressed by the reciprocation motion of piston driven by the crankshaft, and then it discharges the compressed gas to the discharge line.

There are two types of reciprocating compressors are for a general purpose. Single acting reciprocating compressor and double acting reciprocating compressor. In single-acting type, the compressor cylinder usually arranged in the vertical position while in double acting the compression cylinders are normally arranged in horizontal.

Construction and working of reciprocating compressor:

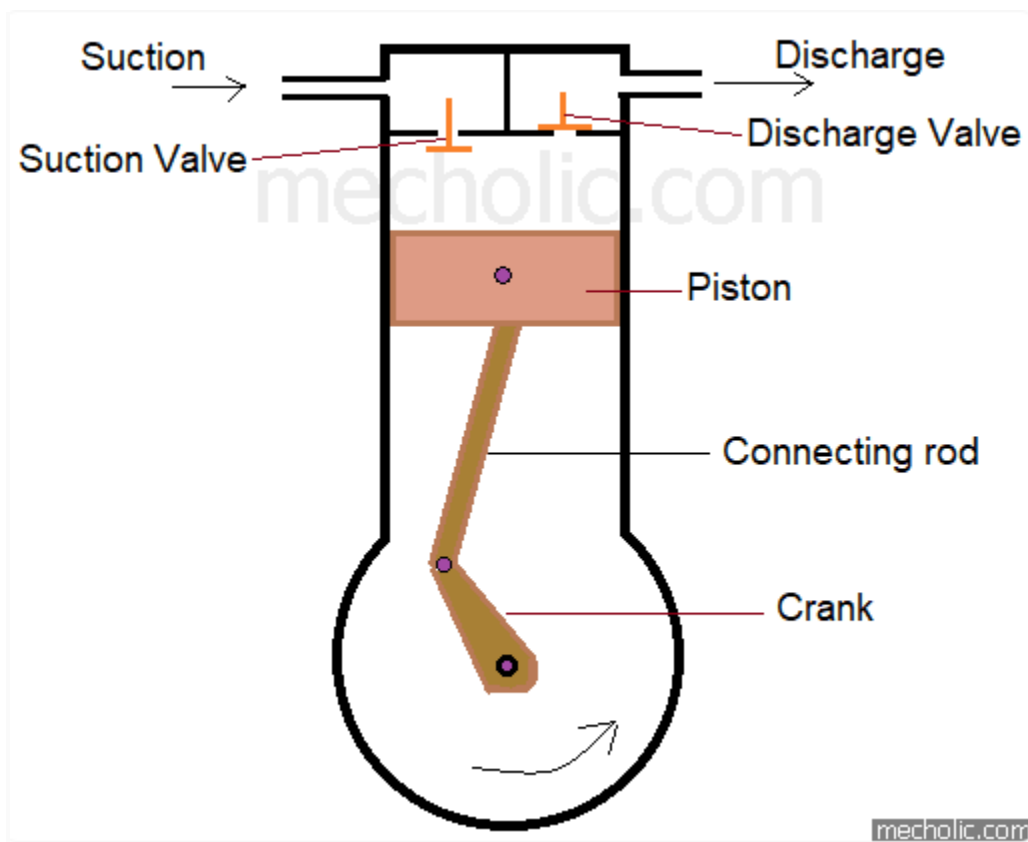

Figure shows the line drawing of the simplest form of a reciprocating compressor. It consists of a piston, inlet-outlet valves, cylinder with an adequate cooling arrangement, connecting rod and crank. The pistons are fitted with [piston rings](#) to avoid gas leakage. Both valves are designed to quick and leak-free operation. The piston is connected to crank through the connecting rod. A prime mover (engine, or motor) runs the crankshaft and it is connected to connecting rod. This arrangement transfer the rotation of the engine to reciprocating motion of piston.

The working of this compressor is same as the compression stroke of [two-stroke engine](#). The working cycle of the reciprocating simple reciprocating compressor is described below.

Let us assume the compressor starts when the piston is at top of the cylinder, TDC (Top dead center). In this position, both the suction valve and discharge valve is in a closed position. When piston starts to move downward from TDC to the bottom side of the cylinder BDC (Bottom dead center) the residual gas (refrigerant) from the previous cycle in the cylinder gets expanded which reduce the pressure inside the cylinder. At the same time, the suction valve is opened and the large amount of fresh gas is flowed into the cylinder. The flow will continue until the piston reaches the Bottom.

At BDC of stroke, the suction valve again gets closed. Now the piston moves from BDC to TDC (compression stroke), the cylinder volume decreases, pressure increases and the gas get compressed. When the pressure inside the cylinder exceeds the pressure on the top of the discharge valve, the discharge valve gets opened and the compressed gas is flow to the discharge line. For a single acting reciprocating compressor both suction and compression stroke of completed in one revolution of the crankshaft.

Reciprocating compressor used to produce high-pressure gas output. Reciprocating compressor is mainly used in the refrigeration cycle. It is widely used in oil refineries, gas pipelines, natural gas processing plants, chemical plants, etc. it is also used in blowing of the plastic bottle.

Principle of working and constructional details of Rotary compressor:

Rotary compressor is the type of [positive displacement compressor](#). As the name suggests, rotary compressor produces compressed fluid/ refrigerant by the rotary movements of blades or the movement of eccentric roller connected to the motor shaft. Since the clearance volume for a rotary compressor is negligible, its volumetric efficiency is high compared to the [reciprocating compressor](#). Normally the prime mover (motor) and the compressor is pressed into a single cylinder with no vapor space between compressor and shell. So they are also small and light. One of the most important features of the rotary compressor is that it lacks the suction and discharge valves as used on the reciprocating compressor.

The general construction of the rotary compressor has a cylinder with an intake and discharge port, and it has a roller inside the cylinder. The roller rub against the inside wall of the cylinder while it rotates. The fluid (refrigerant) is get trapped between the space between rotor and cylinder. The trapped fluid is then progressively get compressed by decreasing the annular space between the rotor and cylinder. The process can be described in four intermediate steps.

Cylinder

Roller

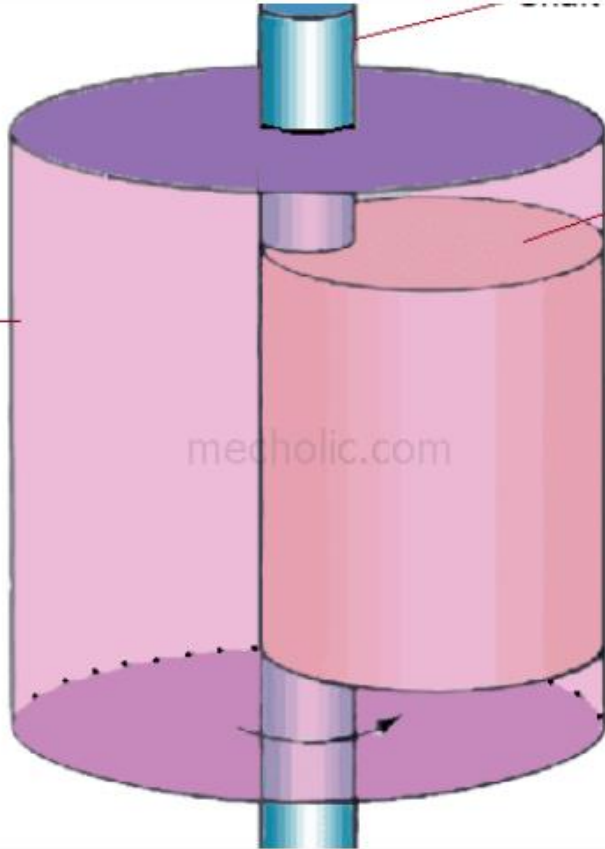

mecholic.com



1. Introduction of fluid into the compartment between roller and cylinder.
2. Sealing the suction port and trapping the fluid inside the chamber.
3. Compression of fluid by decreasing the volume of the chamber.
4. Discharging of high-pressure fluid through the discharge port.

There are mainly two types of rotary compressor

1. Stationary blade type rotary compressor
2. Rotating blade type rotary compressor

The rotary compressor is usually arranged as a single unit, sometimes it arranged as series of the compressor with or without an intercooler.

4.1.2 Centrifugal compressor:

Centrifugal compressor working on Bernoulli's fluid dynamic principle. Bernoulli's principle derived from conservation of energy. In a centrifugal compressor, an additional kinetic energy imparted to the fluid by rotating impeller. Then this kinetic energy gets converted into pressure energy at diffuser.

In a centrifugal compressor, the impeller is connected to a shaft driven by any mechanism. The rotating impeller draws air through the inlet at the center of the impeller and guides the air towards the periphery. During this movement, impeller increases the kinetic energy of air.

At the periphery, the air is guided through a stationary passage known as diffuser where its velocity kinetic energy decreases. According to Bernoulli's law reduction in a velocity cause increase in pressure of the fluid, that is kinetic energy is converted into pressure energy.

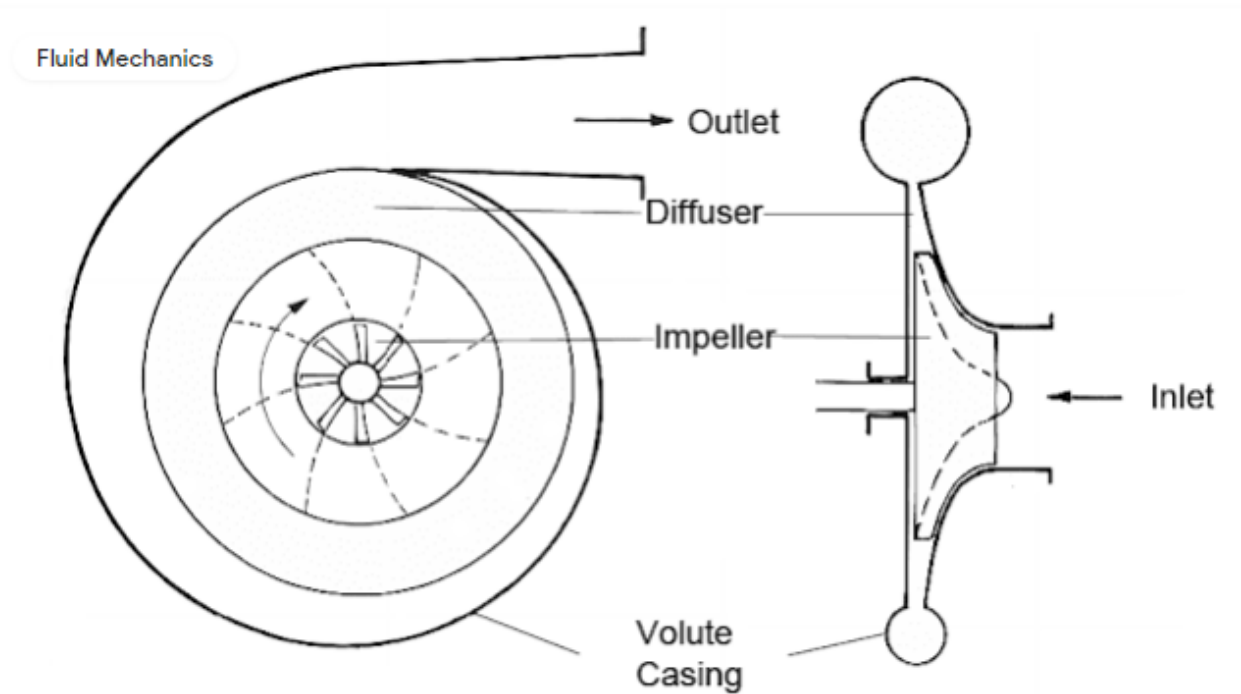

Centrifugal compressor schematic diagram

4.1.3 Important terms:

5. The following important terms are frequently used in air compressors:

- **Inlet Pressure:** It is the absolute pressure of air at the inlet of a compressor.

6.

7. **Discharge Pressure:** It is the absolute pressure of air at the outlet of a compressor.

8.

9. **Compression Ratio or Pressure Ratio:** It is the ratio of discharge pressure to the inlet pressure. Since the discharge pressure is always more than the inlet pressure, therefore the compression ratio is more than unity.

10.

11. **Compressor capacity:** it is the volume of air delivered by a compressor and is expressed in cubic meter per minute or cubic meter per second.

12.

13. **Free air delivery:** It is the actual volume delivered by a compressor when reduced to the normal temperature and pressure conditions. The capacity of a compressor is generally given in terms of free air delivery.

14.

15. **Swept volume:** It is the volume of air sucked by the compressor during its suction stroke.

16. **Mean Effective pressure:** It is the ratio of the work done per cycle to the stroke volume of the compressor.

4.2 CONDENSERS

4.2.1 Working principle and constructional details of air cooled condenser:

The working principle of Air Cooled Condenser is to distribute the exhaust steam from the steam turbine straightly to the steam condensers in several rows through ducting. At the same time, the large axial-flow fans intake air and sweep over the tube bundles externally to carry away heat. In tube bundles, the exhaust steam gradually changes to condensates and is accumulated in the condensate tank through the bottom headers. Moreover, the vacuum of the whole Air cooled condenser (ACC) covers by the air evacuation system. For this reason, the steam turbine can activate smoothly and confirm power generation efficiency.

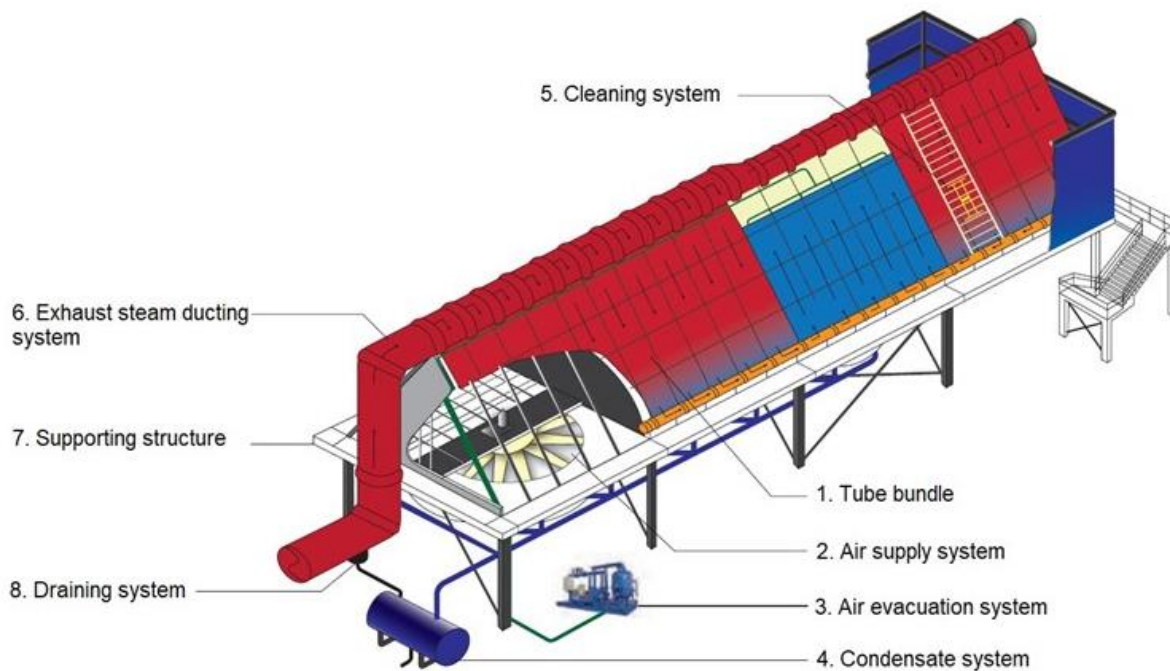

4.2.2 Heat rejection ratio(HRR):

4.2.3 Cooling tower and Spray ponds:

Cooling water:

Consider the cooling tower on top of a typical office type building. A centrifugal pump moves water, known as “condenser water”, between the chiller in the basement and the cooling tower on the roof. The chiller adds heat to the condenser water and the cooling tower cools it down by rejecting this into the atmosphere. The heat it rejects is all the unwanted heat from the building caused by the people, computers, sunlight, lighting etc. It must also reject the heat generated by the compressor of the chiller. The condenser water leaves the condenser of the chiller at around 32°C (89.6°F) and the pump sends this up to the cooling tower. The system has been designed so that the condenser water leaving the cooling tower and re-entering the chiller condenser, must be around 27°C (80.6°F) in order to be able to pickup enough heat on it’s next cycle.

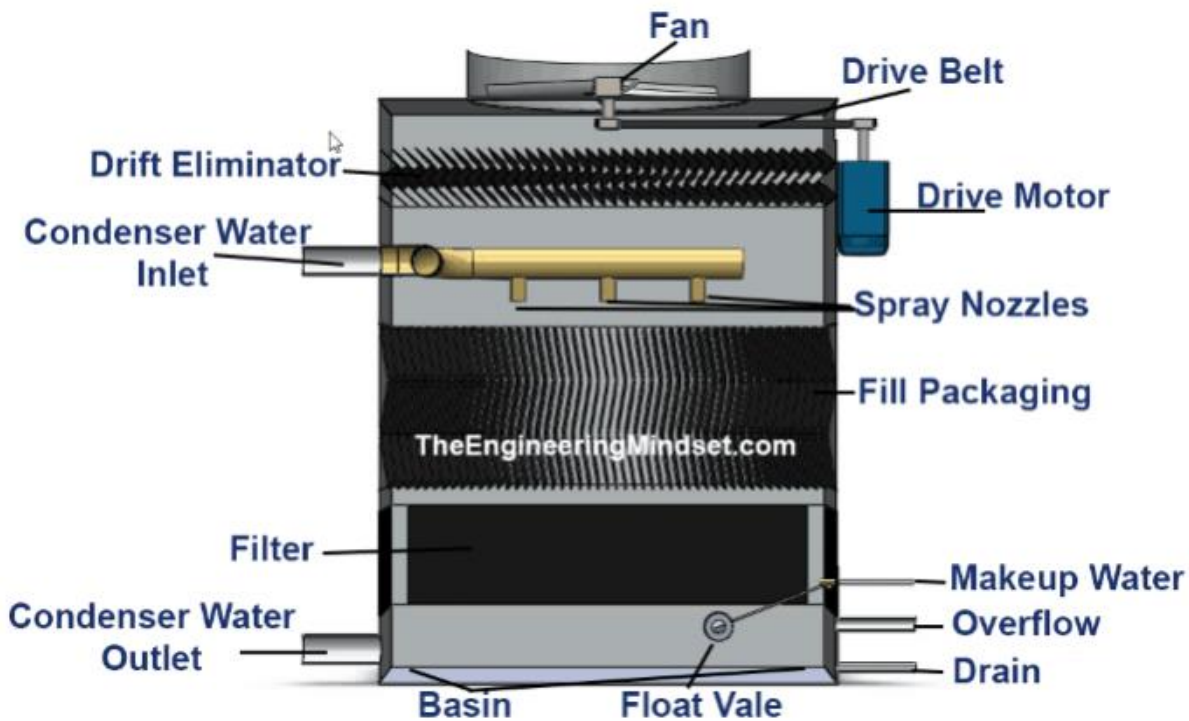

Spray pond:

A **spray pond** is a [reservoir](#) in which warmed [water](#) (e.g. from a [power plant](#)) is cooled before reuse by spraying the warm water with nozzles into the cooler [air](#). Cooling takes place by exchange of heat with the ambient air, involving both [conductive heat transfer](#) between the water droplets and the surrounding air and [evaporative cooling](#) (which provides by far the greatest portion, typically 85 to 90%, of the total cooling). The primary purpose of spray pond design is thus to ensure an adequate degree of contact between the hot injection water and the ambient air, so as to facilitate the process of heat transfer.

The spray pond is the predecessor to the natural draft [cooling tower](#), which is much more efficient and takes up less space but has a much higher construction cost. A spray pond requires between 25 and 50 times the area of a cooling tower. However, some spray ponds are still in use today.



4.3 EVAPORATORS

4.3.1 Principle of working and constructional details of an evaporator:

The function of the evaporator is to absorb the heat from the space or surrounding medium which is to be cooled by means of refrigeration. The process of heat removal from the substance to be cooled or refrigerated is done in the evaporator. The liquid refrigerant is vaporized inside the evaporator (coil or shell) in order to remove heat from a fluid such as air, water etc. Evaporators are manufactured in different shapes, types and designs to suit a diverse nature of cooling requirements. Thus, we have a variety of types of evaporators, such as prime surface types, finned tube or extended surface type, shell and tube liquid chillers, etc

Construction:

The evaporator as shown in the figure is the part of the refrigeration system where the refrigerant vaporizes as it picks up heat. Heated air is forced through and past the fins and tubes of the evaporator. The heat from the air is picked up by the boiling refrigerant and is carried in the system to the condenser. The evaporator is usually installed in housing under the dash panel.

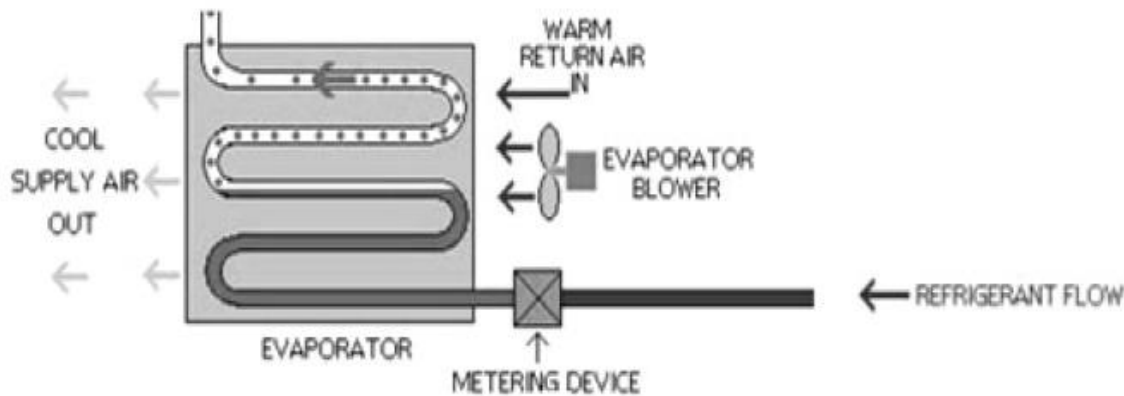

Figure: Evaporator

Working of Evaporator:

When the air conditioning system is turned on, warm air from the passenger compartment is blown through the coils and fins of the evaporator. The evaporator receives refrigerant from the thermostatic expansion valve or orifice tube as low pressure, cold atomized liquid. As the cold refrigerant passes through the evaporator coil, heat moves from the warm air into the cooler refrigerant. When the liquid refrigerant receives enough heat, a change of state – from a low-pressure liquid into a low-pressure vapor – takes place.

The thermostatic expansion valve or orifice tube continually meters the precise amount of refrigerant necessary to maintain optimum heat transfer, which ensures that all of the liquid refrigerants will have changed to a vapor by the time it reaches the evaporator outlet. The vaporized refrigerant then continues on to the inlet (suction) side of the compressor.

4.3.2 Type of evaporator based on construction:

1. Bare tube evaporator
2. Plate evaporator
3. Finned tube evaporator
4. Shell tube evaporator
5. Tube in tube evaporator

1. Bare tube evaporator

Bare tube evaporator: The bare tube evaporators are made up of copper tubing or steel pipes. The copper tubing is used for small evaporators where the refrigerant other than ammonia is used while the steel pipes are used with the large evaporators that uses ammonia as refrigerants. The evaporator comprises of several turns of tubing and are usually used for liquid chilling. In blast cooling and freezing operations, atmospheric air flows over bare tube evaporator and the chilled air leaving it used for cooling purposes.

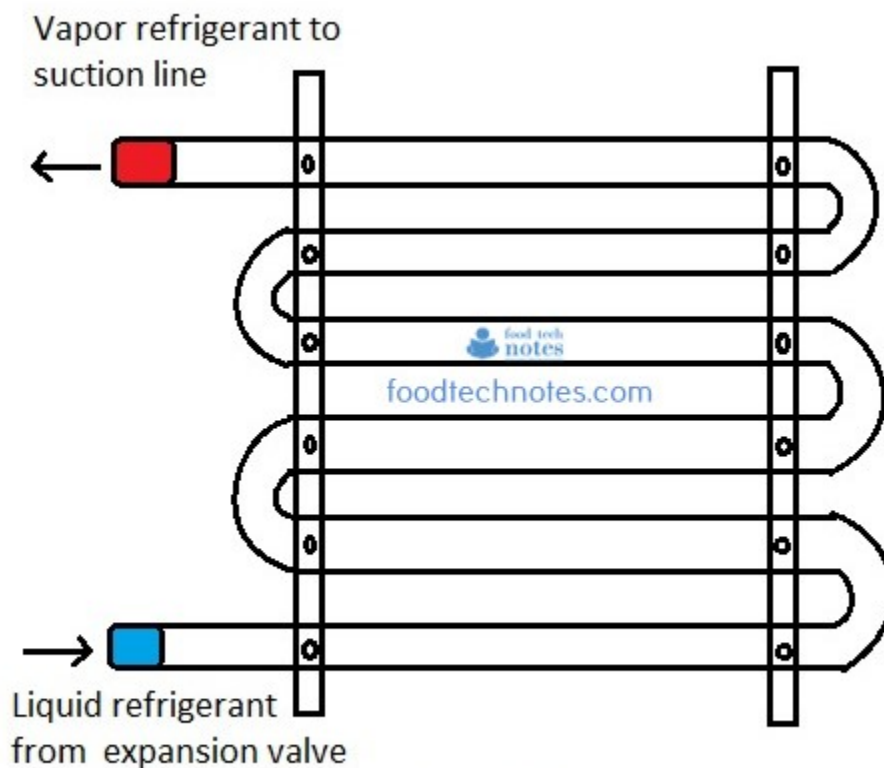

Fig: Bare tube evaporator

Finned tube evaporator:

The finned evaporators are tube type evaporators covered with the fins. When the fluid (air or water) to be chilled flows over the bare tube evaporator, lots of cooling effect from the refrigerant goes wasted since there is less surface for transfer of heat from fluid to refrigerant. The fins on the finned tube evaporator increases contact surface area and increases heat transfer rate. Thus finned evaporators are more effective than bare tube evaporators.

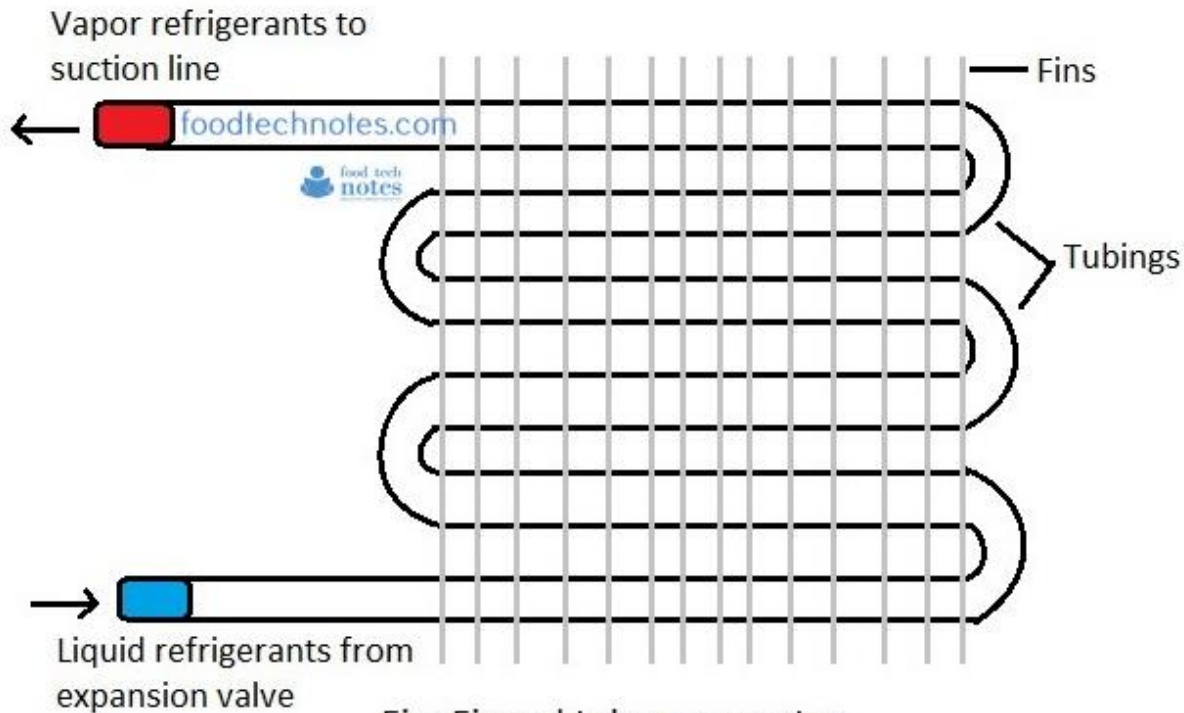
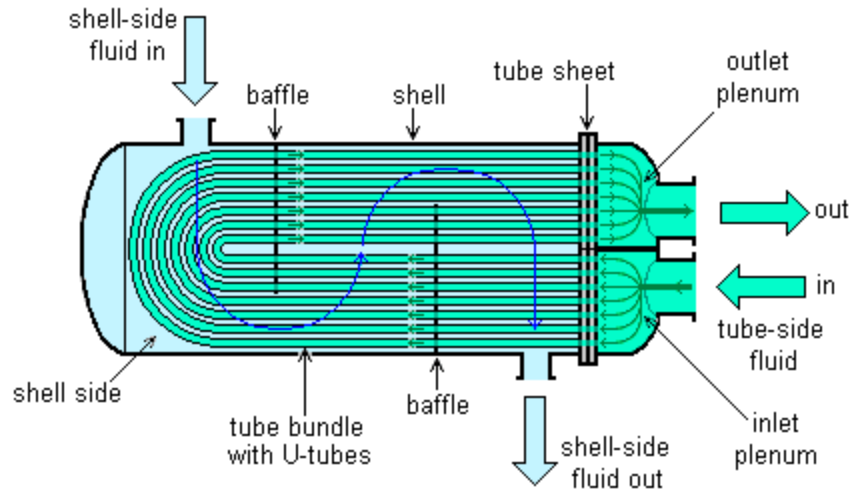

Fig: Finned tube evaporator

Shell and tube heat exchanger design [\[edit\]](#)

There can be many variations on the shell and tube design. Typically, the ends of each tube are connected to [plenums](#) (sometimes called **water boxes**) through holes in [tubesheets](#). The tubes may be straight or bent in the shape of a U, called U-tubes.

U-tube heat exchanger



In nuclear power plants called [pressurized water reactors](#), large heat exchangers called [steam generators](#) are two-phase, shell-and-tube heat exchangers which typically have U-tubes. They are used to boil water recycled from a surface condenser into steam to drive a [turbine](#) to produce power. Most shell-and-tube heat exchangers are either 1, 2, or 4 pass designs on the tube side. This refers to the number of times the fluid in the tubes passes through the fluid in the shell. In a single pass heat exchanger, the fluid goes in one end of each tube and out the other.

Straight-tube heat exchanger (one pass tube-side)

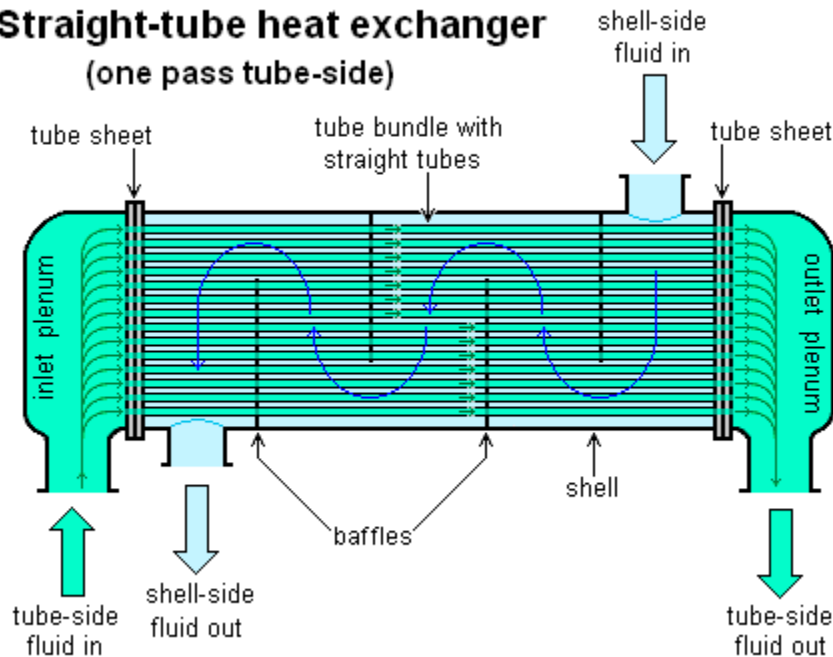

Surface condensers in power plants are often 1-pass straight-tube heat exchangers (see [surface condenser](#) for diagram). Two and four pass designs are common because the fluid can enter and exit on the same side. This makes construction much simpler.

Straight-tube heat exchanger (two pass tube-side)

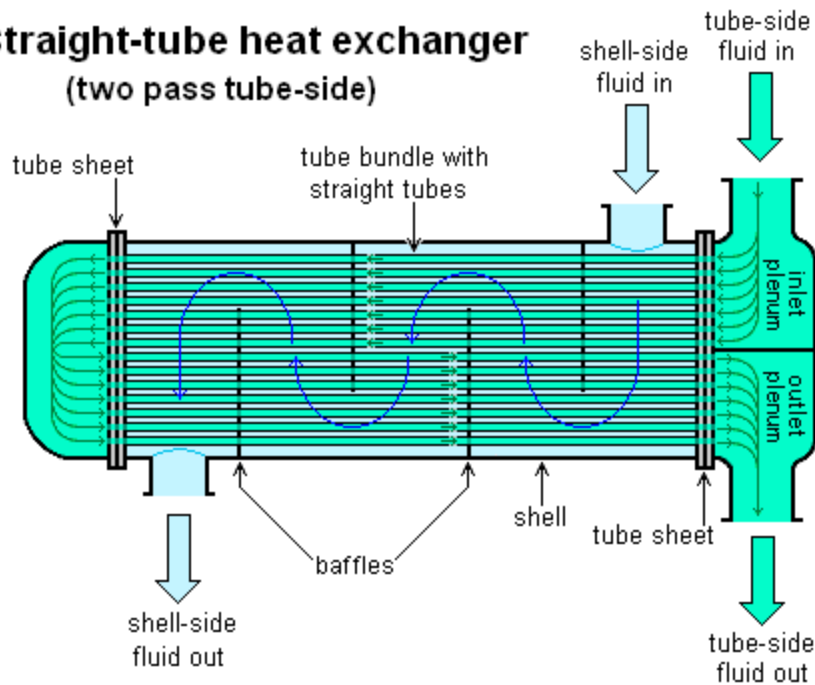

There are often [baffles](#) directing flow through the shell side so the fluid does not take a short cut through the shell side leaving ineffective low flow volumes. These are generally attached to the tube bundle rather than the shell in order that the bundle is still removable for maintenance.

Countercurrent heat exchangers are most efficient because they allow the highest [log mean temperature difference](#) between the hot and cold streams. Many companies however do not use two pass heat exchangers with a u-tube because they can break easily in addition to being more expensive to build. Often multiple heat exchangers can be used to simulate the [countercurrent flow](#) of a single large exchanger.

Questions for exercise/assignment:

Short questions

1. What is function of compressor.
2. Mention industrial uses of compressor.
3. What is function of condenser.
4. What is function of evaporator.
5. What is function of spray pond.

Long questions

1. Briefly explain working of Reciprocating air compressor.
2. Briefly explain working of finned type evaporator.

REFERENCES:

- <https://www.mecholic.com/2019/03/reciprocating-compressors-working.html>
- <https://www.gmsthailand.com/product/air-cooled-condenser-acc/>
- <https://www.pharmaguideline.com/2007/02/principle-construction-working-uses-merits-demerits-of-climbing-film-evaporator.html>

5.0 REFRIGERANT FLOW CONTROLS, REFRIGERANTS & APPLICATION OF REFRIGERANTS

5.1 EXPANSION VALVES

5.1.1 Capillary Tube:

A capillary tube is a long, wound-up copper tube with a tiny opening that receives hot, high-pressure liquid refrigerant

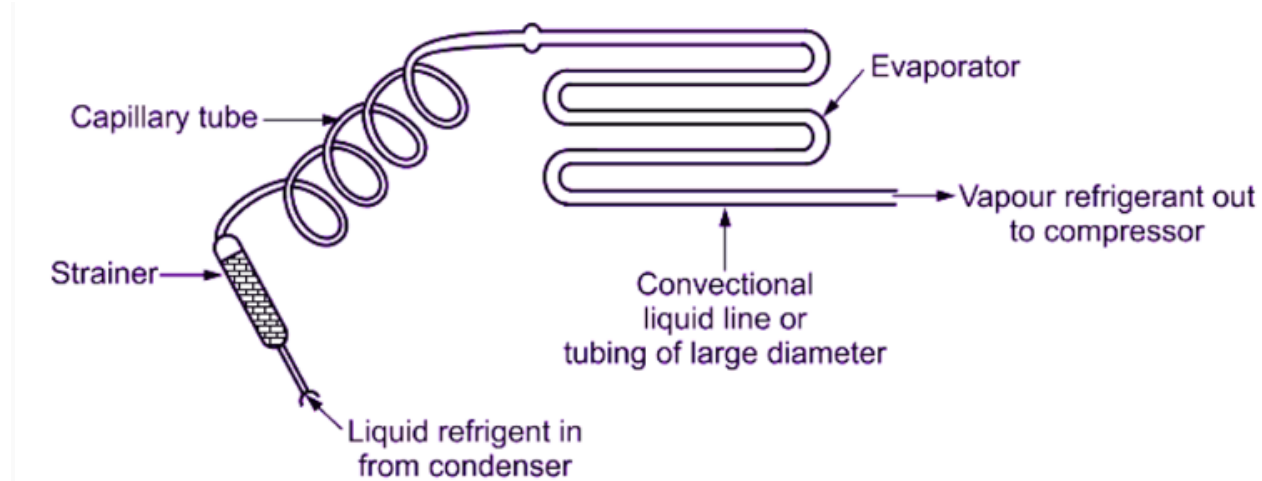

t from the condenser. This small opening holds high pressure on one side of the tube and low pressure on the opposite side. The friction from the walls of the tube rapidly reduces the pressure of the refrigerant flowing through it.

It is installed on the suction line. A filter-drier is sometimes fitted before the tube to remove dirt or moisture from the refrigerant.

This device is simple, and does not have any moving parts and lasts longer. For using this device, the amount of refrigerant in the system must be properly calibrated at the factory level.

5.1.2 Automatic expansion valve:

Automatic Expansion Valve regulates the flow of refrigerant from the liquid line to the evaporator by using a pressure-actuated diaphragm. It maintains a constant pressure in the evaporator.

These types of expansion valves consist of a needle with a seat and a pressure bellows or diaphragm with a torsion spring capable of adjustment. Operated by evaporator pressure their chief disadvantage is their relatively poor efficiency compared with other types.

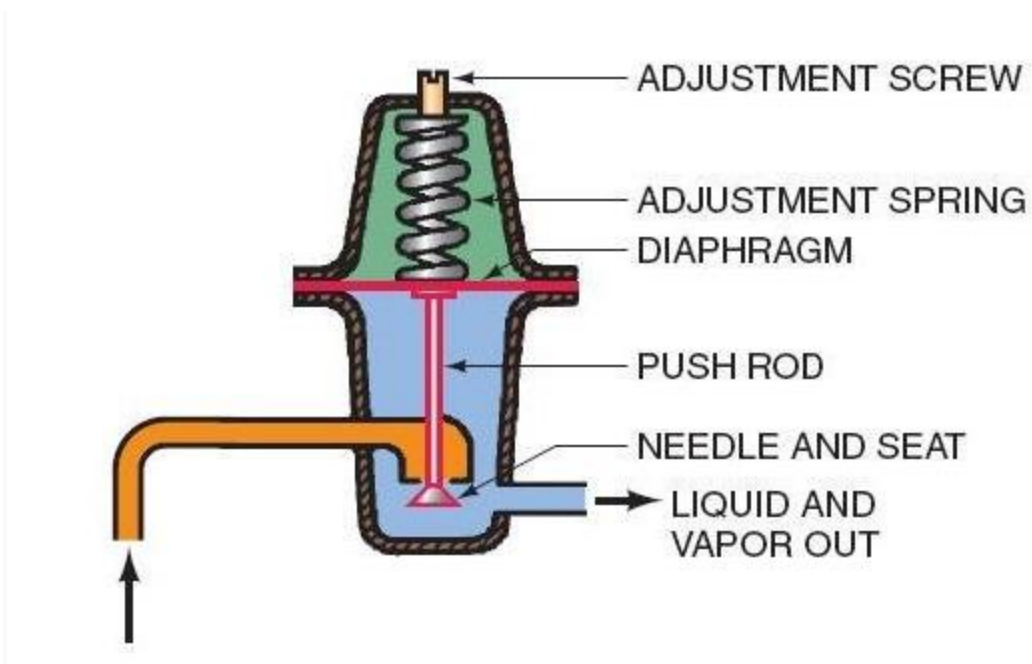

Constant pressure in the evaporator also requires a constant rate of vaporization, which in turn calls for severe throttling of the liquid. There is also the danger of liquid being allowed to return to the compressor when the load falls below a certain level.

The setback is that it is not efficient if the load fluctuates, thus this type is not suitable in air conditioning as the load fluctuates a lot during its operation. It is used principally in small equipment with constant loads, such as domestic storage cabinets and freezers.

5.1.3 Thermostatic expansion valve:

A thermostatic expansion valve is a device that controls the amount of refrigerant released into the evaporator and is intended to regulate the superheat of the vapor leaving the evaporator. Although often described as a “thermostatic” valve, an expansion valve does not regulate temperature; the temperature of the evaporator will vary with the evaporation pressure

These types of expansion valves are popular due to their simplicity and availability, and their relatively good sensitivity and accuracy in regulation. The large choice of expansion valve sizes and bulb charges means the capacity and temperature ranges are very good. The disadvantage of TEVs is the necessity for relatively high superheating, which steals the heat transfer area from the evaporation process.

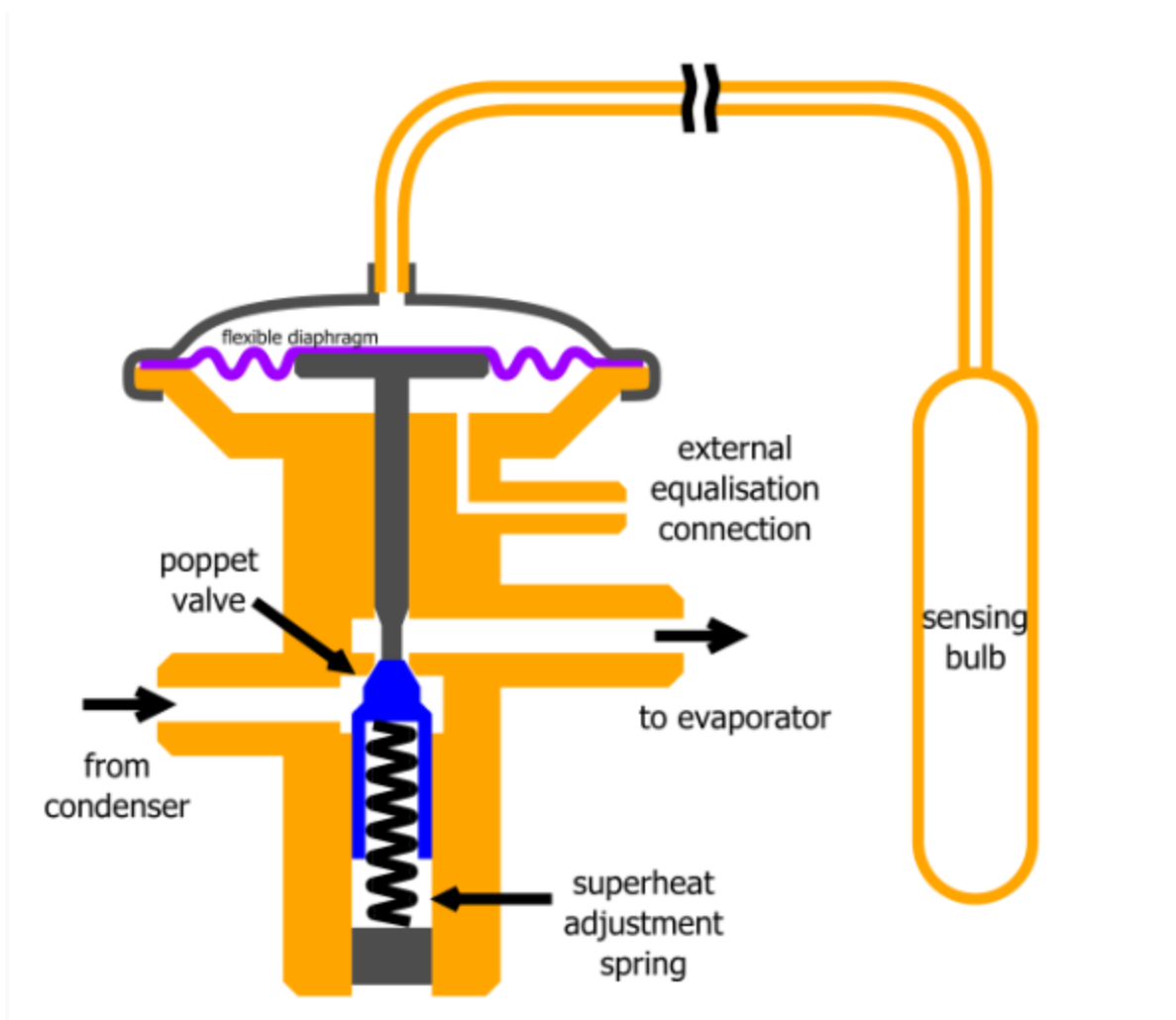

The TEV strives to maintain a stable level of superheating inside the evaporator under all conditions by adjusting the mass flow of refrigerant in response to the evaporator load. This is achieved by a membrane inside the valve housing, which compares the temperature before and after the evaporator. To be able to compare the pressures before and after the evaporator, the TEV has to be combined with another device, a bulb. The difference in pressure between the saturation pressure of evaporation and the pressure of the bulb is balanced across a membrane inside the head of the valve. The movement of the membrane controls the position of a needle and hence the mass flow of refrigerant entering the evaporator.

5.2 REFRIGERANTS:

5.2.1 Classifications of refrigerants:

The refrigerants are classified as follows:

- Primary refrigerants
- Secondary refrigerants

- **Primary refrigerants:**

Primary refrigerants are those working mediums or heat carriers which directly take part in the refrigeration system and cool the substance by the absorption of latent heat, e.g. *Ammonia, Carbon dioxide, Sulphur dioxide, Methyl chloride, Methylene chloride, Ethyl chloride and Freon group* etc.

The Primary refrigerants are grouped below:

- (i) **Halo-carbon compounds:**

In this group are included refrigerants which contains one or more of three halogens, chlorine and bromine and they are sold in the market under the names as Freon, Genetron, Isotron and Areton. Since the refrigerants belonging to this group have outstanding merits over the other group's refrigerants, therefore they find wide field of application in domestic, commercial and industrial purpose.

The list of the halo-carbon refrigerants commonly used is given below:

- R10 -- Carbon tetra chloride (CCl_4)
- R11 -- Tri-chloro monofluoro methane (CCl_3F)
- R12 -- Di-chloro difluoro methane (CCl_2F_2)
- R13 -- Chlorotrifluoromethane (CClF_3)
- R21 -- Di-chloro mono-fluoro methane (CHCl_2F)
- R22 -- Mono chloro difluoro methane (CHClF_2)
- R30 -- Methylene Chloride (CH_2Cl_2)
- R40 -- Chloromethane (CH_3Cl)
- R100 -- Ethyl chloride ($\text{C}_2\text{H}_5\text{Cl}$)
- R113 -- Trichloro trifluoro ethane ($\text{C}_2\text{F}_3\text{Cl}_3$)
- R114 -- Tetra- fluoro dichloroethane ($\text{C}_2\text{F}_4\text{Cl}_2$)
- R152 -- Di fluoro ethane ($\text{C}_2\text{H}_4\text{F}_2$)

- (ii) Azeotropes:**

The refrigerants belonging to this group consists of mixture of different substances. These substances cannot be separated into components by distillation. They possess fixed thermodynamic properties and do not undergo any separation with changes in temperature and pressure. An azeotrope behaves like a simple substance.

Example: R-500. It contains 73.8% of R-12 & 26.2% of R-152.

- (iii) Hydrocarbons:**

Most of the refrigerants of this group are organic compounds. Several hydrocarbons are used successfully in commercial and industrial installation. Most of them possess satisfactory thermodynamic properties but are highly inflammable. Some of the important refrigerants of this group are:

- R50 -- Methane (CH_4)
- R170 -- Ethane (C_2H_6)
- R290 -- Propane (C_3H_8)

- R600 -- Butane (C₄H₁₀)
 - R601 -- Pentane (C₅H₁₂)
- (iv) Inorganic Compound:**

Before the introduction of hydrocarbon group these refrigerants were most commonly used for all purposes. The important refrigerants of this group are:

- R717 -- Ammonia (NH₃)
- R718 -- Water (H₂O)
- R729 -- Air (Mixture of O₂, N₂, CO₂)
- R744 -- Carbon Di Oxide (CO₂)
- R764 -- Sulphur dioxide (SO₂)

(v) Unsaturated Organic Compound:

The refrigerants belonged to this group possess ethylene or propylene as their constituents. They are

- R1120 -- Trichloroethylene (C₂HCl₃)
- R1130 -- Dichloroethylene (C₂H₂Cl₂)
- R1150 -- Ethylene (C₂H₄)
- R1270 -- Propylene (C₃H₆)

• **Secondary refrigerants:**

Secondary refrigerants are those circulating substances which first cooled with the help of the primary refrigerants and are then employed for cooling purpose, e.g. *ice, solid carbon dioxide* etc. These refrigerants cool substances by absorption of their sensible heat.

5.2.2 Desirable properties :

- (i) Low specific volume of vapour
- (ii) Low specific heat
- (iii) High thermal conductivity
- (iv) Low viscosity
- (v) High electrical insulation
- (i) Ease of leakage location
- (ii) Availability and low cost
- (iii) Ease of handling
- (iv) High COP
- (v) Low power consumption per tonne of refrigeration
- (vi) Low pressure ratio and pressure difference

5.2.3 Designation of refrigerant:

Designation of Refrigerant are followed by certain numerals e.g., R-11, R-12, R-22 Saturated hydrocarbon Refrigerant : The chemical formula The designation of the refrigerant is : R- (m-1) (n+1) p Where n+p+q = 2m+2 m = Number of carbon atoms, n = Number of hydrogen atoms, P = Number of fluorine atoms, q = Number of chlorine atoms.

Unsaturated hydrocarbon Refrigerant : The chemical formula The designation of the refrigerant is : R- 1 (m-1) (n+ 1) p Where n+p+q = 2m Inorganic Refrigerant : R 700+ molecular Wt.

5.2.4. Thermodynamic Properties:

- (i) Low boiling point
- (ii) Low freezing point
- (iii) Positive pressures (but not very high) in condenser and evaporator.
- (iv) High saturation temperature
- (v) High latent heat of vapourization

5.2.5 Chemical Properties:

- (i) Non-toxicity
- (ii) Non-flammable and non-explosive
- (iii) Non-corrosiveness
- (iv) Chemical Stability in reacting
- (v) No effect on the quality of stored (food and other) products

03. Physical Properties:

- (i) Low specific volume of vapour
- (ii) Low specific heat
- (iii) High thermal conductivity
- (iv) Low viscosity
- (v) High electrical insulation

5.2.6 Commonly used refrigerants

R-11, Trichloro-monocfluoro-methane(CCl_3F):The R-11 is a synthetic chemical product which can be used as a refrigerant. It is stable, non-flammable and non-toxic. It is considered to be low pressure refrigerant. R-11 is safest cleaning solvents that can be used for this purpose. The cylinder colour code for R-11 is orange.

R-12, Dichloro-difluoro-methane(CCl_2F_2):The R-12 is a very popular refrigerant. It is a colorless, almost odorless liquid with boiling point -29°C at atmospheric pressure. It is a non-toxic, non-corrosive, non-irritating and non-flammable. The refrigerant is available in variety of cylinder sizes and the cylinder colour code is white.

R-22, Monochloro-difluoro-methane(CHClF_2):The R-22 is a man-made refrigerant developed for refrigeration installations that need a low evaporating temperature, as in fast freezing units which maintains a temperature of -29°C to -40°C . It has also been successfully used in air conditioning units and in households refrigerators. The leaks may be detected with a soap solution, a halide torch or electronic leak detector. The cylinder colour code for R-22 is green.

R-134a, Tetrafluoro-ethane($\text{CF}_3\text{CH}_2\text{F}$): The R-134a is considered to be the most preferred substitute for refrigerant R-12. Its boiling point is -26°C which is quite close to the boiling point of R-12 which is -29°C at atmospheric pressure. It has lower suction pressure and large suction vapour volume. Since the molecules of R-134a are smaller than R-12, therefore a very sensitive leak detector is used for to detect leaks.

R-717(Ammonia): The R-717, i.e. ammonia (NH₃), is one of the oldest and most widely used of all the refrigerants. Its greatest application is found in large and commercial reciprocating compression system where high toxicity is secondary. It is also widely used in absorption systems. It is a chemical compound of nitrogen and hydrogen under ordinary conditions, it is a colorless gas. Its boiling point at atmospheric pressure is -33°C. The low boiling point makes it possible to have refrigeration at temperature below 0°C without using pressure.

5.2.7 Substitute for CFC:

- Substitutes for CFCs in electronics: carbon dioxide
- Substitutes for CFCs foam-blowing: water, carbon dioxide, hydrocarbons, HCFCs
- Substitutes for CFCs in refrigeration and air-conditioning: HCFCs initially, hydrofluorocarbons (HFCs), hydrocarbons, and ammonia

5.3 Applications of refrigeration

5.3.1 Cold storage:

Cold storage is a facility that primarily stores food items that are short-lived and highly likely to get spoilt under normal conditions. These may include fruits, vegetables, fish, meat etc. These food items are stored under optimum temperature (primarily low) and humid environment as required for individual items.

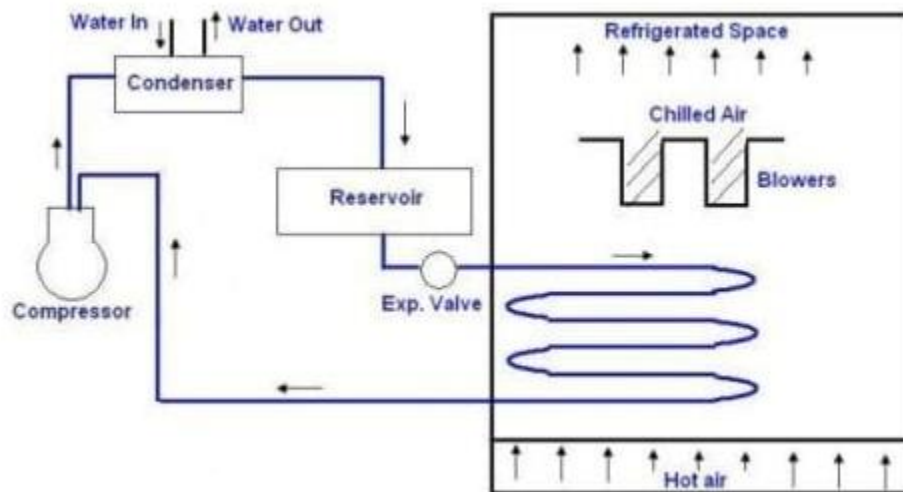

5.3.2 Dairy refrigeration:

Storage of milk and milk products requires maintaining low temperature in the cold storages depending on the type of product to be stored. e.g. milk is stored at around 3-4 °C while ice-cream is stored at -30 °C temperature.

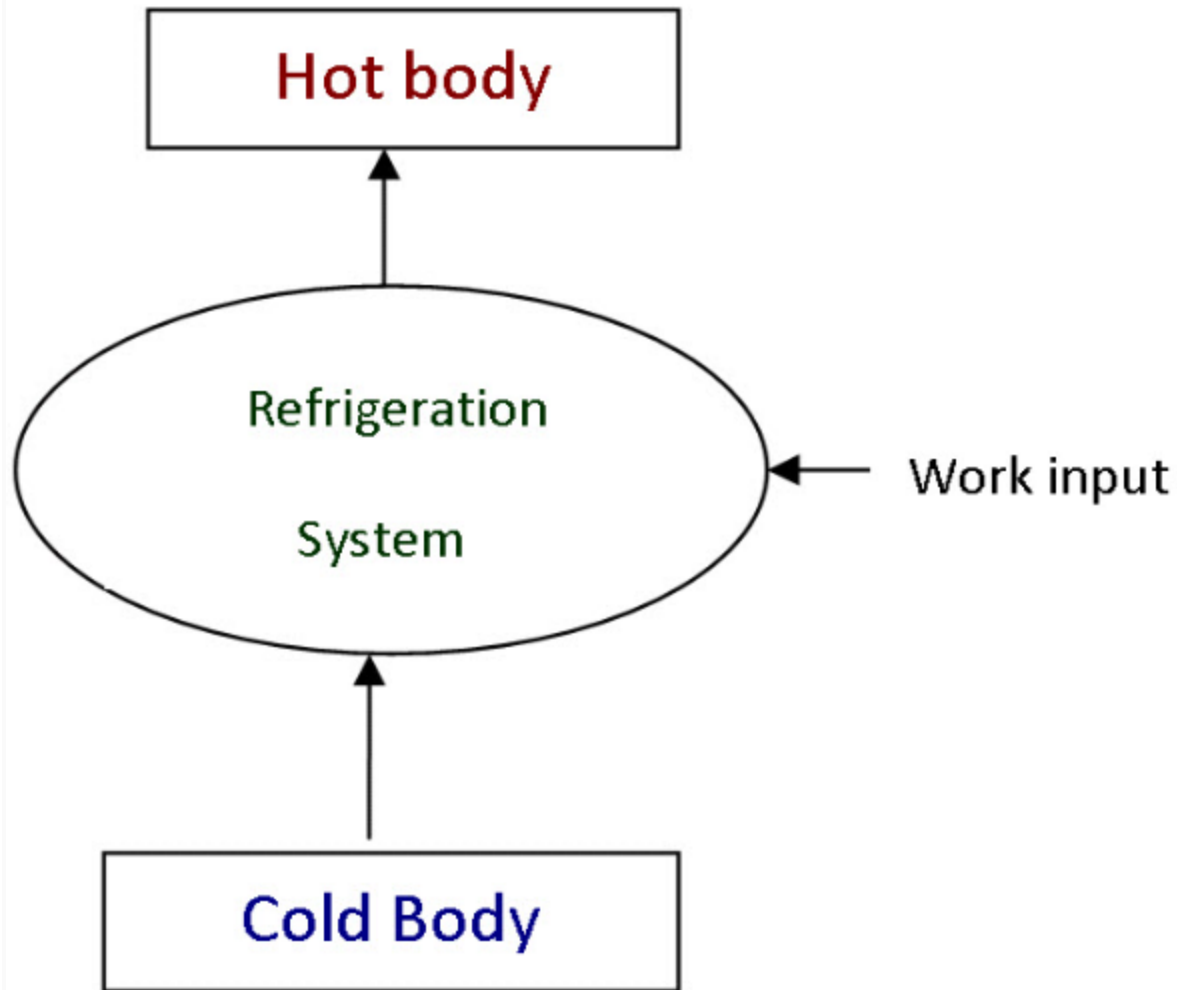

5.3.3 Ice plant:

This resource will make you familiar with how big-sized 'Ice plates' are manufactured. This ice-making process involves heat transfer/extraction from the water with the help of basic refrigeration techniques. This ice plant uses 'brine' and 'Ammonia' as refrigerants, and working medium alternatively.

The function of an ice plant or ice factory is to make or form ice in large quantities and in large sizes. The ice-making process is quite similar to the one we observe in a [domestic refrigerator](#). The only difference lies in the ice-making stage. In the freezer compartment, the tray with water when it comes in contact with the very low-temperature environment becomes ice but in an ice plant which is a huge commercial factory, it uses separate ice making or ice freezing circuits. The cold is produced in one circuit using a vapor compression refrigeration cycle and it is transferred to the water cans by another circuit by secondary refrigerants.

- Ammonia: It is the primary refrigerant that takes heat from brine and gives it to the primary circuit. This ammonia changes phase while moving in the circuit
- Brine: It is the secondary refrigerant that takes heat from the water and produces ice. Brine can be of either NaCl or CaCl₂

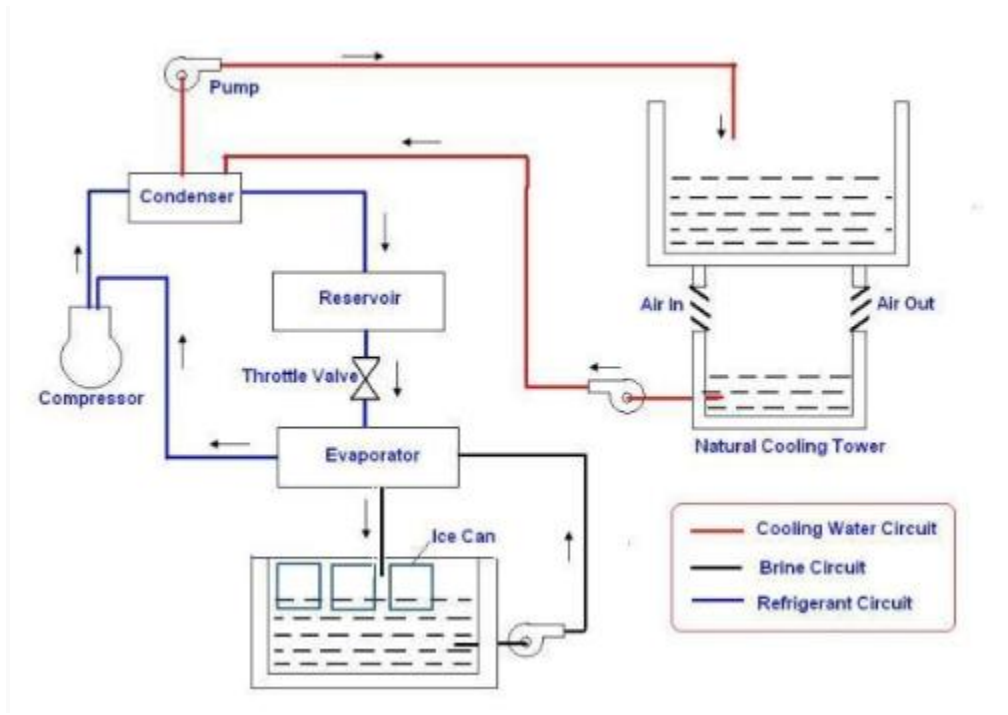

Ice plant is a big size domestic refrigerator freezer. The working principle of ice making is the same as that of the domestic refrigerator but the ice making is done by taking heat from water using a brine solution and this water now gets converted into ice.

5.3.4 Water cooler:

The working principle of the water cooler is based upon the vapour compression refrigeration cycle. The refrigerant is compressed by the compressor and is delivered to the condenser which is cooled by a fan. The high pressure liquid after being cooled by a condenser is collected in a receiver from where it goes to the expansion valve. The expansion valve takes the required quantity of the refrigerant depending upon the load on the evaporator.

As the refrigerant passed through the expansion valve, its temperature falls down considerably (up to -10°C). Its pressure also falls down. Then this liquid refrigerant passes through the evaporator coils, which surround the water tank (water may be stored in it). The liquid refrigerant in the coils absorbs its latent heat from the water, leaving it cooled.

The liquid refrigerant as it flows through the evaporator coils is converted into vapour and by the time it leaves the coils, it is almost converted into dry vapour. This vapour is again compressed through the compressor. This way this cycle is repeated again and again. The cooled water may be drained out and the fresh water may be added to the tank for cooling.

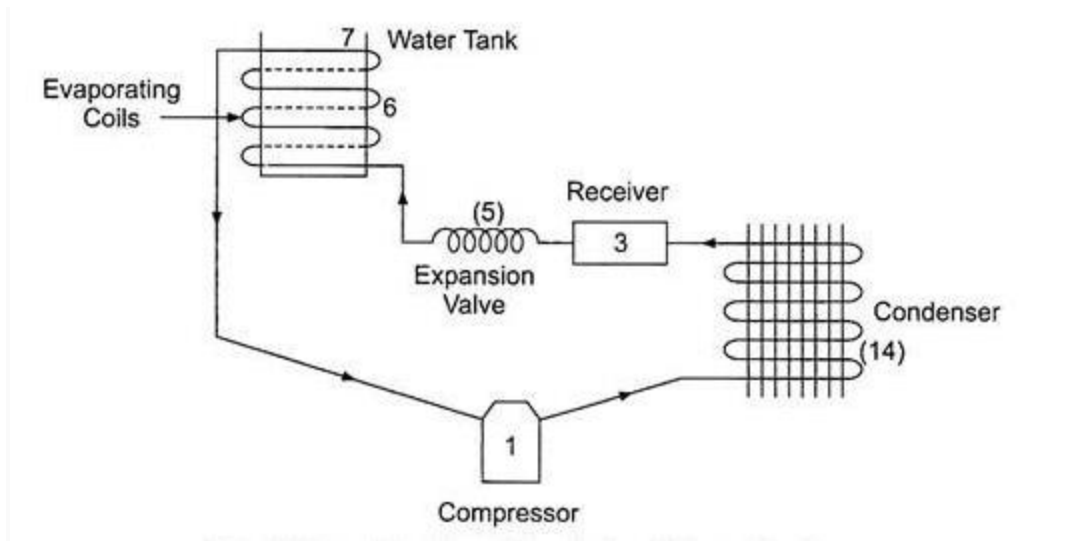

5.3.5 Frost free refrigerator:

Owing to the new-age technology, a frost-free fridge offers an even distribution of cool air within the refrigerator by means of electric fans. Since this technology prevents the formation of ice, no defrosting is necessary.

In a different variant of this technology, the refrigerator comes with three crucial parts – a timer, a heating coil and a temperature sensor.

After every six hours or thereabouts, the timer turns the heating coil on which is wrapped among the freezer coils. The heater melts the ice frosted on it and after a certain level of heat, the temperature sensor senses the rise in temperature and turns off the heater. This method, however, consumes more power and also affects the food stored inside the refrigerator.

- Single door frost-free refrigerators are rare to come by since this technology is more suited for double door refrigerators, which are ideal for bigger families.
- Due to the frost-free refrigeration feature, only a selected (controlled) portion of air emanating from the freezer makes it to the refrigerator.

There are several advantages of buying frost-free refrigerators.

- Customers don't have to manually defrost the frost build-up in frost-free fridges. Thus, over time, the power consumption will not increase.
- Because of the frost-free refrigeration, it is much easier to see the food packaging. Furthermore, the frozen food do not stick together.
- Due to constant air circulation in frost-free refrigerators, the probability of experiencing bad odours in the fridge remains less.
- You can manage the temperature better in a frost-free refrigerator.

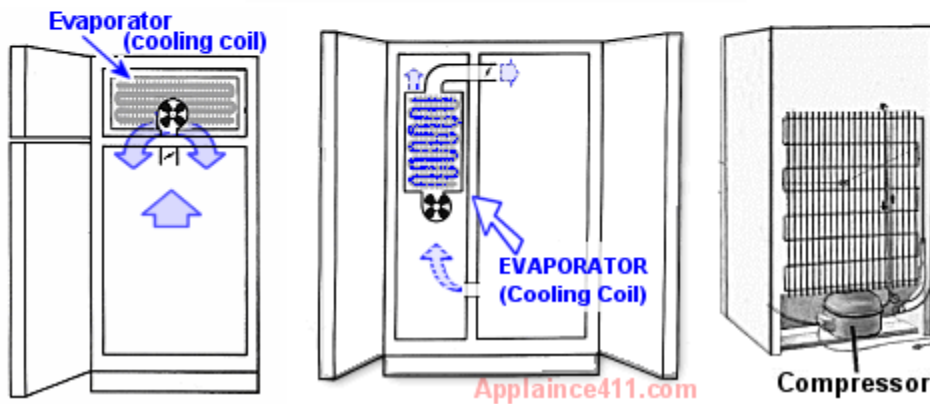
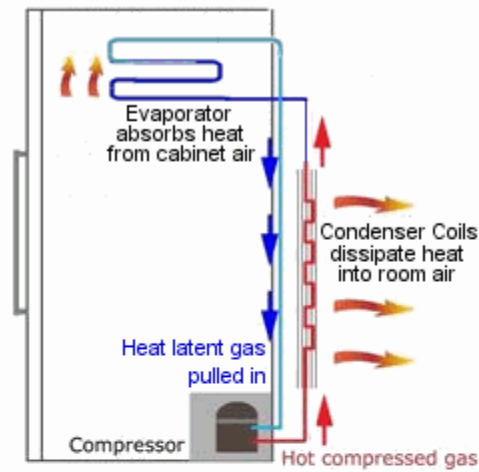

Questions for exercise/assignment:

Short questions

1. What is the colour code of cylinder for R-11.
2. What is the chemical name of R-22.
3. What is function of Ice Plant.
4. What is function of water cooler.
5. What is function of cold storage.

Long questions

1. Briefly explain about commonly used refrigerant.
2. Briefly explain working of frost free refrigerator.

REFERENCES:

- <https://www.linquip.com/blog/types-of-expansion-valves-guide/>
- <https://mechaengineeringonline.blogspot.com/2016/02/classifications-of-refrigerant.html>
- <https://www.indiastudychannel.com/resources/145551-Construction-and-working-of-an-Ice-Plant>
- <https://www.engineeringenotes.com/electrical-engineering/electrical-appliances/water-cooler-parts-and-working-appliances-electrical-engineering/24326>
- <https://www.bajajfinservmarkets.in/discover/journals/blogs/e-com/what-are-frost-free-refrigerators-and-how-do-they-work/>

6.0 PSYCHOMETRICS AND COMFORT AIR CONDITIONING SYSTEM

6.1 Psychometrics terms

Psychrometry is the science of studying thermodynamic properties of moist air and the use of these to analyze humid air conditions and processes.

Air conditioning processes can be determined with [psychrometric charts](#) and [Mollier diagrams](#). Common properties in the charts includes

- dry-bulb temperature
- wet-bulb temperature
- relative humidity (RH)
- humidity ratio
- specific volume
- dew point temperature
- enthalpy

With at least two known properties it is possible to characterize the air in the intersection of the property lines - the **state-point**. With the intersection point located on the chart or diagram other properties can be read directly.

Dry-Bulb Temperature, usually referred to as **the** air temperature, is the air property that is most commonly used. People referring to air temperature normally referring to Dry Bulb Temperature.

Dry-Bulb Temperature - T_{db} - can be measured by using a normal thermometer. With Dry-Bulb Temperature the sensible heat content in the air can be determined along the bottom axis of the psychrometric chart. The vertical lines extending upward from this axis are constant-temperature lines.

Wet-Bulb Temperature - T_{wb}

Wet-Bulb Temperature is associated with the moisture content of the air.

Wet Bulb Temperature can be measured with a thermometer that has the bulb covered with a water-moistened bandage with air flowing over the thermometer.

Wet-Bulb Temperatures are always lower than dry bulb temperatures with less than 100% relative humidity in the air. The Wet-Bulb Temperature and the Dry-Bulb Temperature will be identical with 100% relative humidity in the air (the air is at the saturation line).

On the chart, the Wet-Bulb Temperature lines slopes a little upward to the left, and the temperature is read at the saturation line.

Relative Humidity - RH

Relative Humidity is the ratio of the mass of water vapor contents in the humid air - m_w - to the maximum possible mass of vapor - m_{wmax} - at the actual pressure and temperature. Relative humidity can also be expressed as the ratio of water vapor pressure - p_w , to the water vapor pressure of saturated air at the same temperature - p_{ws} .

Relative humidity is expressed as a percentage.

The moisture-holding capacity of air increases with air temperature. In practice the relative humidity will indicate the moisture level of the air compared to the maximum moisture-holding capacity of air at saturation.

Note ! The moisture holding capacity of air **increases dramatically** with temperature! - important for drying processes.

The relative humidity lines in the psychrometric chart are curved lines that move upwards to the right. The line representing saturated air where the relative humidity - RH is 100% - is the uppermost curved line in the chart.

Dew Point Temperature - T_{dp}

Dew Point is the temperature at which water vapor starts to condense in the air - the temperature at which air becomes completely saturated. Above this temperature the moisture stays in the air.

The Dew Point Temperature can be read in the psychrometric charts by following the horizontal line from the state-point to the saturation line. The Dew Point Temperature is represented along the 100% relative humidity line.

Specific Volume of Humid Air - v

Specific Volume represents the space occupied by a unit weight of dry air ($ft^3/lb, m^3/kg$). Specific volume is indicated along the bottom axis of the psychrometric chart with the constant-volume lines slanting upward to the left.

enthalpy - h

Enthalpy is the measure of the total thermal energy in air.

Energy content is expressed as energy per unit weight of air ($Btu/lb_{air}, J/kg_{air}$).

Enthalpy in the psychrometric chart can read from where the appropriate wet-bulb line crosses the diagonal scale above the saturation curve.

Air with the same amount of energy may either be drier hotter air (higher sensible heat) or cooler moister air (higher latent heat).

6.2 Adiabatic saturation of air by evaporation of water:

In adiabatic saturation/evaporative cooling we get a cooling of the air as sensible heat is used as latent heat of vaporization to evaporate the moisture at the grain kernel surface. This moisture is removed by the moving air. This transfer is due to differences in vapour pressure between the grain and the drying air. The vapour pressure in the grain depends on grain moisture content and temperature.

In effect then, one has simultaneous heat and mass transfer in the drying process. Heat transfer in the drying operation will occur through the flow of heat as a result of convection, conduction or radiation or, in some cases, as a result of a combination of any of these effects.

Mass transfer on the other hand, depends on two mechanisms: the movement of moisture internally within the product which is a function of its internal physical nature and its moisture content; and the movement of water vapour from the surface as a result of external conditions of temperature, air humidity and flow, area of exposed surface, and air pressures. In a drying operation either of these

mechanisms may be a limiting factor on the rate of drying although they are proceeding simultaneously throughout the drying cycle.

6.3 Psychrometric chart and uses:

A psychrometric chart presents physical and thermal properties of moist air in a graphical form. It can be very helpful in troubleshooting and finding solutions to greenhouse or livestock building environmental problems. Understanding psychrometric charts can help you visualize environmental control concepts, such as why heated air can hold more moisture or, conversely, how allowing moist air to cool will result in condensation. This fact sheet explains how characteristics of moist air are used in a psychrometric chart. Three examples are used to illustrate typical chart use and interpretation. Properties of moist air are explained in the *Definitions Sidebar* for your reference during the following discussions.

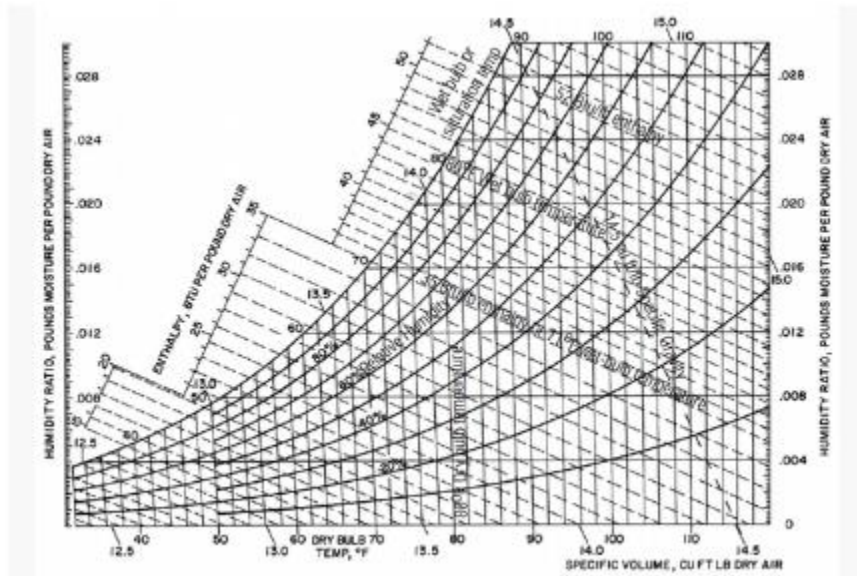

6.4 Psychrometric processes:

6.4.1 Sensible cooling and heating

The cooling of air without any change in its specific humidity, is known as sensible cooling. Let air at temperature t_{d1} , passes over a cooling coil of temperature t_{d3} as shown in Fig. 16 (a). It may be noted that the temperature of air leaving the cooling coil (t_{d2}) will be more than t_{d3} . The process of sensible cooling, on the psychrometric chart, is shown by a horizontal line 1-2 extending from right to left as shown in Fig

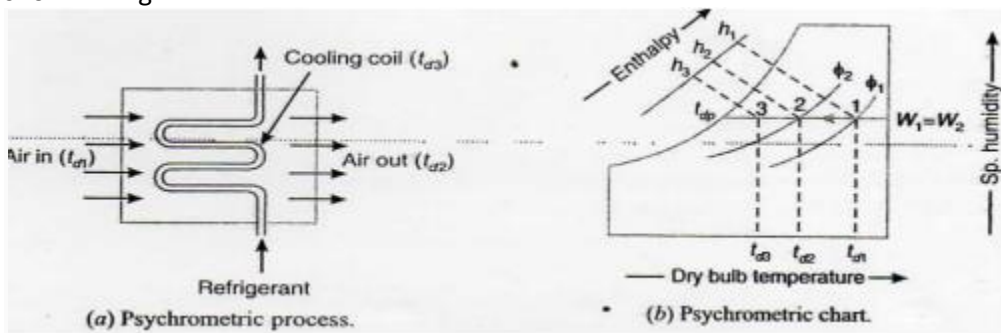

The heating of air, without any-change in its specific humidity, is known as sensible heating. Let air at temperature t_{d1} , passes over a heating coil of temperature t_{d3} , as shown in Fig. 15 (a). It may be noted that the temperature of air leaving the heating coil (t_{d2}) will be less than t_{d3} . The process of sensible heating, on the psychrometric chart, is shown by a horizontal line 1-2 extending from left to right as shown in Fig.15 (b). The point 3 represents the surface temperature of the heating coil. The heat absorbed by the air during sensible heating may be obtained from the psychrometric chart by the enthalpy difference ($h_2 - h_1$) as shown in Fig. 15 (b). It may be noted that the specific humidity during the sensible heating remains constant (i.e. $W_1 = W_2$).

The dry bulb temperature increases from t_{d1} , to t_{d2} and relative humidity reduces from ϕ_1 , to ϕ_2 as shown in Fig. . The amount of heat added during sensible heating may also be obtained from the relation

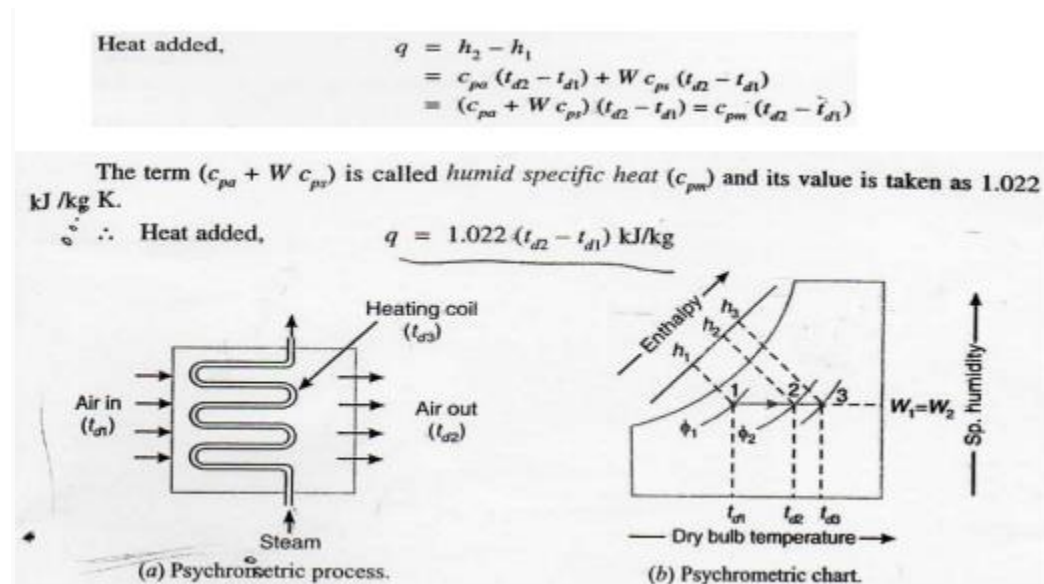

6.4.2 Cooling and Dehumidification:

a psychrometric process that involves the removal of water from the air as the air temperature falls below the dew- point temperature.

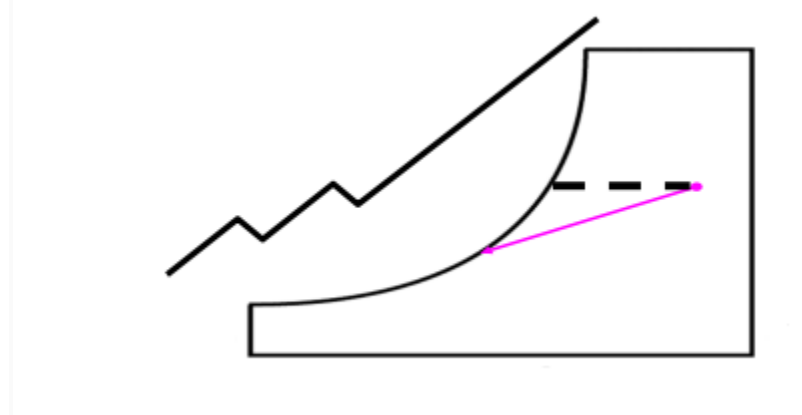

6.4.3 Heating and Humidification:

a psychrometric process that involves the simultaneous increase in both the dry bulb temperature and humidity ratio of the air.

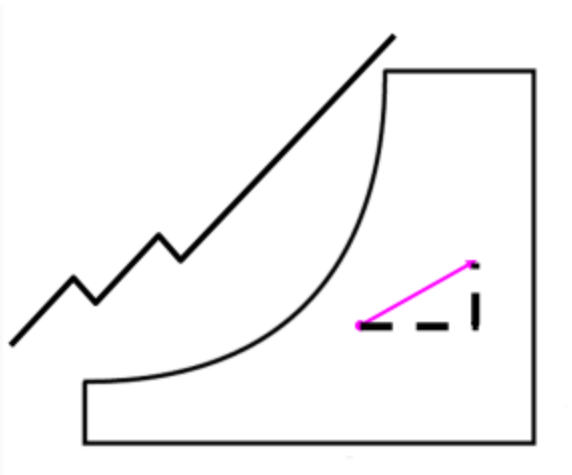

6.4.4 Adiabatic cooling with humidification:

As the name implies, during this process, the air temperature drops and its humidity increases. This process is shown in Fig.28.6. As shown in the figure, this can be achieved by spraying cool water in the air stream. The temperature of water should be lower than the dry-bulb temperature of air but higher than its dew-point temperature to avoid condensation ($T_{DPT} < T_w < T_o$).

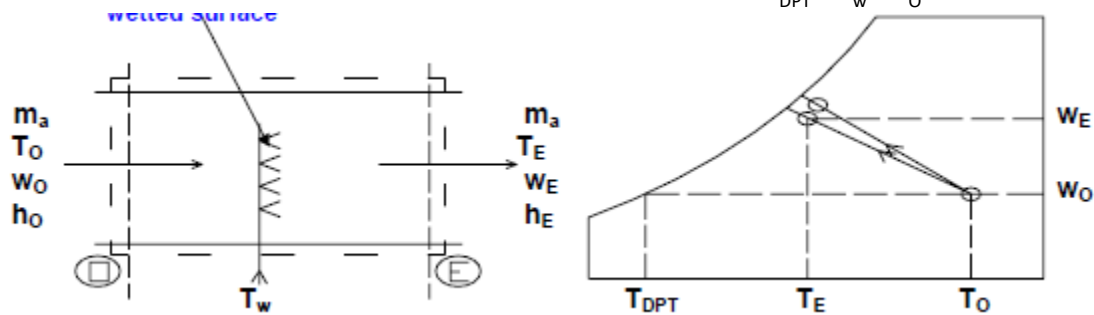

6.4.5 Total heating of a cooling process:

This process can be achieved by using a hygroscopic material, which absorbs or adsorbs the water vapor from the moisture. If this process is thermally isolated, then the enthalpy of air remains constant, as a result the temperature of air increases as its moisture content decreases as shown in Fig.. This hygroscopic material can be a solid or a liquid. In general, the absorption of water by the hygroscopic material is an exothermic reaction, as a result heat is released during this process, which is transferred to air and the enthalpy of air increases.

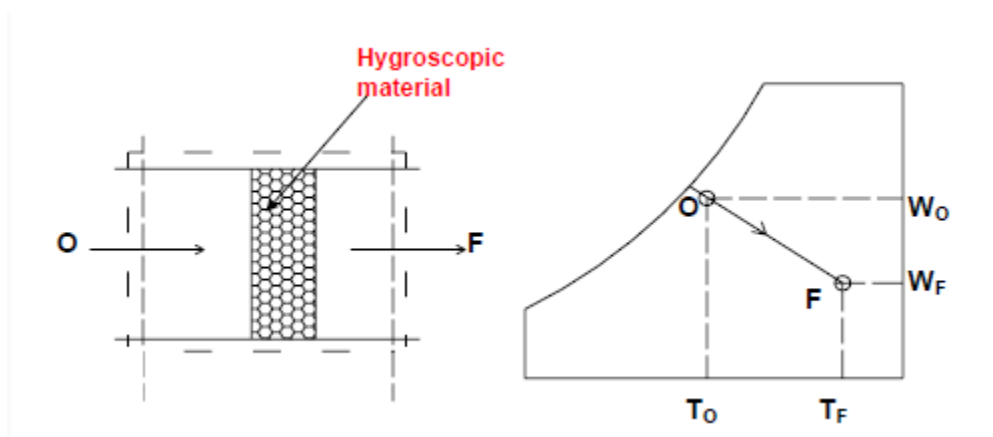

6.4.6 SHF(Sensible Heat Factor):

As a matter of fact, the heat added during a psychometric process may be split up into sensible heat and latent heat. The ratio of the* sensible heat to the total heat is known as Sensible Heat Factor(briefly written as SHF)or sensible heat ratio(Briefly written as SHR). Mthematically
 $SHF = \text{Sensible heat} / \text{Total heat} = SH / (SH + LH)$

Where SH= Sensible heat
LH= Latent heat.

BPF(Bypass Factor):

Bypass Factor is **part of the total air through the coil which fails to come into contact with the surface of the cooling coil**. Apparatus Dew Point (ADP) is the effective surface temperature of the cooling coil. The inability of a coil to cool or heat the air to its temperature is indicated by a factor called by-pass factor (BPF) or Coil Bypass Factor. This inability is due to the coil inefficiency and some amount of air just bypassing the coil without getting affected by it.

6.4.7 Adiabatic mixing:

Mixing of air streams at different states is commonly encountered in many processes, including in air conditioning. Depending upon the state of the individual streams, the mixing process can take place with or without condensation of moisture.

i) Without condensation: Figure shows an adiabatic mixing of two moist air streams during which no condensation of moisture takes place. As shown in the figure, when two air streams at state points 1 and 2 mix, the resulting mixture condition 3 can be obtained from mass and energy balance.

From the mass balance of dry air and water vapor:

$$m_1 + m_2 = m_3 \dots\dots\dots(i)$$

from energy balance

$$m_1 h_1 + m_2 h_2 = m_3 h_3 \dots\dots\dots(ii)$$

fro mass balance of water vapour

$$m_1 W_1 + m_2 W_2 = m_3 W_3 \dots\dots\dots(iii)$$

Substituting value of m_3 from equation (1) and in equation(2),

$$M_1 h_1 + m_2 h_2 = (m_1 + m_2) h_3 = m_1 h_3 + m_2 h_3$$

$$\text{Or } m_1 h_1 - m_1 h_3 = m_2 h_3 - m_2 h_2$$

$$m_1 (h_1 - h_3) = m_2 (h_3 - h_2)$$

$$\text{Therefore } m_1 / m_2 = (h_3 - h_2) / (h_1 - h_3) \dots\dots\dots(iv)$$

Similarly substituting the value of m_3 from equation (1) in equation (3), we have

$$M_1 / m_2 = (W_3 - W_2) / (W_1 - W_3) \dots\dots\dots(v)$$

Now from equation (iv) and (v)

$$m_1 / m_2 = (h_3 - h_2) / (h_1 - h_3) = (W_3 - W_2) / (W_1 - W_3) \dots\dots\dots(vi)$$

6.8 Effective temperature and comfort chart:

Comfort charts are the practical application of concept of effective temperature. This chart is the result of research made on different kinds of people subjected to wide range of environmental temperature, relative humidity and air movement by ASHRAE (American Society of Heating, Refrigeration and Air conditioning Engineers).

The DBT is taken as abscissa and WBT as ordinate. The relative humidity lines are replotted from psychrometric chart. Statistically prepared graphs corresponding to summer and winter season are also superimposed. The chart is prepared showing percentage of people feeling comfort at different effective temperatures.

From comfort chart, engineers find the effective temperature for a point corresponding to a particular DBT, WBT and RH. Now there are several combinations of temperatures and humidity that will have the same effective temperature and will give the same feeling of comfort and warmth.

The chart thus allows engineers to choose most economical room conditions from a zone of suitable comfort conditions for summer and winter.

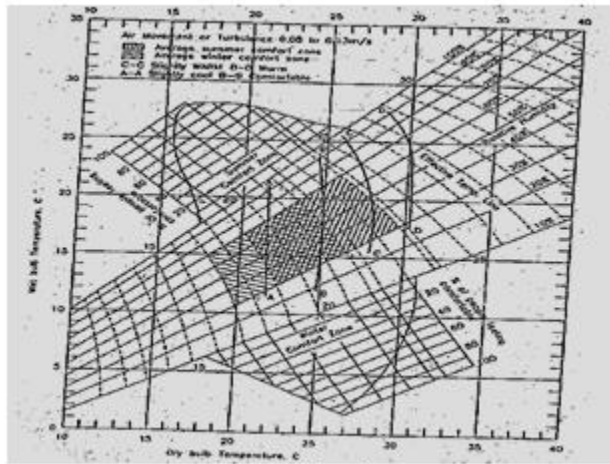

Fig. Comfort Chart

Effective temperature chart:

Chart shows variation in effective temperature with different air velocities. The chart can be read for example, the atmospheric conditions of 24°C DBT and 16°C WBT correspond to about 21°C with nominally still air (velocity 6 m/min) and it is about 17°C at an air velocity of 210 m/min. The same effective temperature means same feeling of warmth, but not the same comfort.

Questions for exercise/assignment:

Short questions

1. Define humidification.
2. Define Bypass Factor.
3. Define SHF.
4. Define dew point depression.
5. Define relative humidity.

Long questions

1. Briefly explain adiabatic mixing of two air streams.
2. Briefly explain about cooling and dehumidification.

REFERENCES:

- https://www.engineeringtoolbox.com/psychrometric-terms-d_239.html
- <https://www.ques10.com/p/35752/what-is-an-effective-temperature-explain-briefly-1/#:~:text=Effective%20temperature%20chart%3A,velocity%20of%2010%20m%2Fmin.>

7 .0 AIR CONDITIONING SYSTEM

7.1 Factors affecting air conditioning system

- (a) Temperature,
- (b) Humidity,
- (c) Purity/cleanliness, and
- (d) Air motion.

(a) Temperature:

The control of temperature is necessary in air conditioning. Even though the outdoor temperature is varying, the indoor temperature is maintained to be constant which is the desired condition. The heat may be either removed or added to the conditioned space depending upon the surrounding conditions. The person may feel comfortable when the temperature is 20°C and relative humidity is 60%.

(b) Humidity:

Humidity control means an increase or a decrease in moisture content inside the space to be air-conditioned. It is necessary not only for human comfort but also to increase the working capability. In summer, the relative humidity should be 60% and in winter it should be 40%.

(c) Purity/Cleanliness:

It is one of the most important factors which affect the air conditioning. In addition to the control of temperature and humidity for human comfort, it is necessary to clean air, i.e., to make the indoor air free from dust, dirt, and odor. It is necessary that proper filtration and purification of air should be done and the supply of air free from dust and dirt should be made in air-conditioned space.

(d) Air Motion:

Air motion or proper circulation of air is also a factor affecting the human comfort. In order to maintain constant temperature throughout the conditioned space, it is necessary that there should be equal distribution of conditioned air in the space. The air movement is maintained at the desirable velocity of about 8 m/min using appropriate distribution system, grills, etc.

7.2 Equipments used in an air-conditioning:

Following are the main equipment or parts used in an air conditioning system:

1. **Circulation fan:** The main function of this fan is to move air to and from the room.
2. **Air conditioning unit:** It is a unit, which consists of cooling and dehumidifying processes for summer air conditioning or heating and humidification processes for winter air conditioning.
3. **Supply duct:** It directs the conditioned air from the circulating fan to the space to be air-conditioned at the proper point.
4. **Supply outlets:** These are the grills, which distribute the conditioned air evenly in the room.
5. **Return outlets:** These are the openings in a room surface which allow the room air to enter the return duct.
6. **Filters:** The main function of the filters is to remove dust, "dirt and other harmful bacteria"s form the air.

7.3 Classification of air-conditioning system:

Following are the types of air conditioning system:

1. Winter air conditioning system.
2. Summer air conditioning system.

Winter Air Conditioning System

Air conditioner working principle In **winter air conditioning system**, the air is burnt and heated, which is generally followed by humidification.

Schematic for the system is arranged.

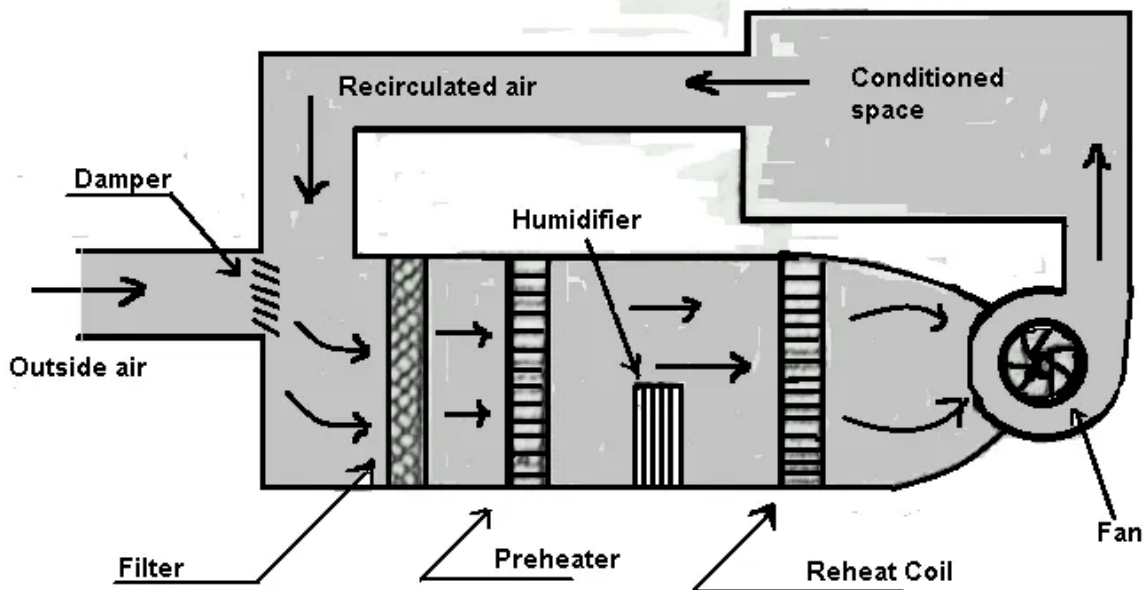

WINTER AIR CONDITIONING SYSTEM

The outside air flows through a damper and mixes with the recirculated air. The mixed air passes through a filter to remove the dirt, dust, and impurities.

The air now passes through a preheat coil to prevent the possible freezing of water and to control the evaporation of water in the humidities. After that, the air is made to pass through a reheat coil to bring the air to the designed dry bulb temperature.

Now, the conditioned air is supplied to the conditioned space by a fan. From the conditioned space, a part of the air is exhausted to the atmosphere by the exhaust fans. The remaining part of the used air is again conditioned and this will repeat again and again.

2 Summer Air Conditioning System:

Air conditioner working principle in summer air conditioning system. In this system, the air is cooled and generally dehumidified. A Schematic for a typical **summer air conditioning system** is arranged.

The outside air flows through the damper and mixed with recirculated air (which is obtained from the conditioned space). The mixed air passes through a filter to remove the dirt, dust and impurities.

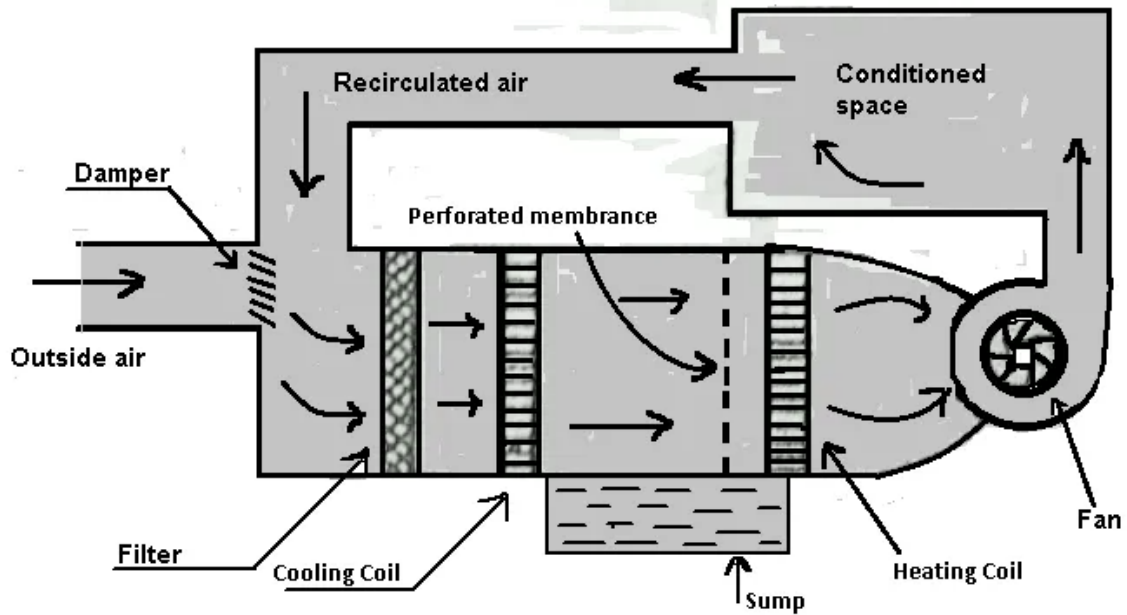

SUMMER AIR CONDITIONING SYSTEM

The air now passes through a cooling coil. The coil has a temperature much below the required dry bulb temperature of the air in the conditioned space.

The cooled air passes through a perforated membrane and loses its moisture in the condensed from which is collected in the sump. After that, the air is made to pass through a heating coil which heats the air slowly.

This is done to bring the air to the designed dry bulb temperature and relative humidity. Now the conditioned air is supplied to the conditioned space by a fan. From conditioned space, a part of the used air is rejected to the atmosphere by the exhaust fan. The remaining air is again conditioned and this repeated for again and again.

The outside air is sucked and made to mix with recirculated air to make for the loss of conditioned air through exhaust fan from the conditioned space.

Questions for exercise/assignment:

Short questions

1. What is the function of a humidifier.
2. What is the function of a de-humidifier.

Long questions

1. Briefly explain the working of Winter air-conditioning with neat diagram.
2. Briefly explain the working of Summer air-conditioning with neat diagram.

·
·

REFERENCES:

- <https://www.engineeringenotes.com/mechanical-engineering/air-conditioning/air-conditioning-definition-factors-and-types-mechanical-engineering/36056>
- <https://www.theengineerspost.com/types-of-air-conditioning-system/>