

# **LAB MANUAL**

# **AUTOMOBILE ENGINEERING**

**Program: Diploma in mechanical engg.**

**Prepared by:**

**Samir Ranjan Behera,**

**Lect. Mechanical Engg.,**

**U.C.P. Engineering School,**

**Berhampur.**

## Experiment No. 1

### **Aim of the experiment:**

To study automobile chassis.

### **Apparatus required:**

Model of automobile chassis.

### **Theory:**

Chassis is the main support structure of the vehicle which is also known as 'Frame'. It bears all the stresses on the vehicle in both static and dynamic conditions. In a vehicle, it is analogous to the skeleton in living organisms. Every vehicle whether it is a two-wheeler or a car or a truck has a chassis-frame. However, its form obviously varies with the vehicle type.

The chassis of an automobile consists of following components suitable mounted.

1. Engine
2. Transmission system consisting of clutch, gear box, propeller shaft, and the rear axle.
3. Suspension system.
4. Road wheels
5. Steering system.
6. Brakes.
7. Fuel tanks.

All the components listed above are mounted in either of the two ways i.e. the conventional construction and frameless or unitary construction.

Conventional construction: In this type of construction the frame is the basic unit to which various components are attached and body is bolted onto the frame later on.

Frameless construction: In this type of construction heavy side members used in conventional construction are eliminated and the floor is strengthened by cross-members and the body, all welded together.

### Functions of the frame:

1. To support the chassis components and the body.
2. To withstand static and dynamic loads without undue deflection.

### Loads on the frame:

1. Weight of the vehicle and the passengers.
2. Vertical loads when the vehicle comes across a bump.
3. Engine torque.
4. Inertia loads due to brake application.
5. Impact loads during collision.
6. Cornering force while taking a turn.

### Frame construction:

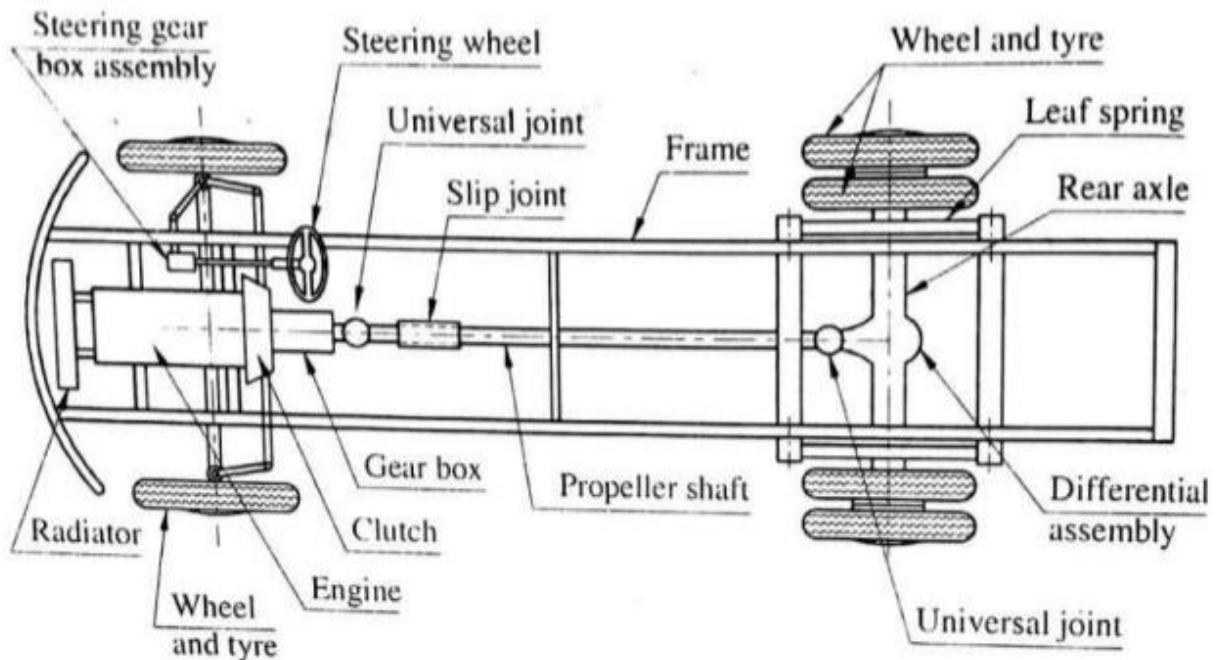

A simplified diagram representing the frame shows the longitudinal members, cross members, engine, clutch, gear box, propeller shaft, differential, rear axle, etc. The engine is usually mounted on the front of the frame. It is supported on the frame at three places by means of rubber blocks. This helps to isolate the engine from road shocks and the body from the engine vibrations.

Various cross sections used for the side members are shown in figure bellow.

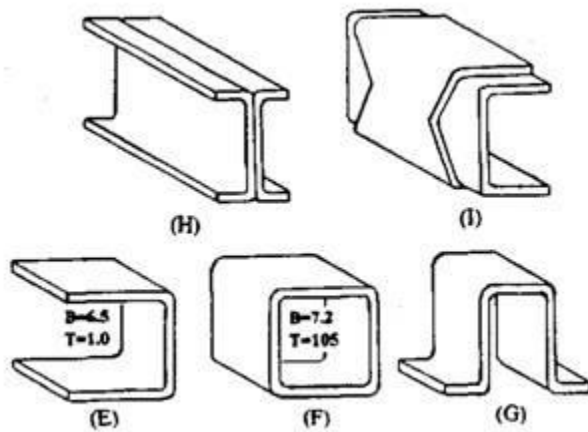

Since the commercial vehicles have to carry large loads, framed construction is invariably used for these.

Materials for frame: Steels used for frames are mild steel sheet, Nickel alloy steel sheet.

**Conclusion:** The chassis of the automobile was studied successfully.

## Experiment no. 2

### **Aim of the experiment:**

To study differential mechanism of an automobile.

### **Apparatus required:**

Model of differential mechanism.

### **Theory:**

#### Components of differential:

1. Pinion gear.
2. Ring gear/Crown wheel.
3. Spider gear/planet gear (It moves in 2 ways i.e. about its own axis and along with ring gear).
4. Side gear/sun gear.

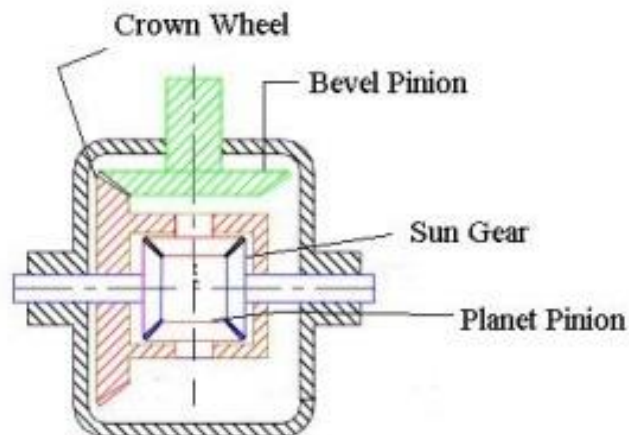

***Fig: Differential gear Assembly***

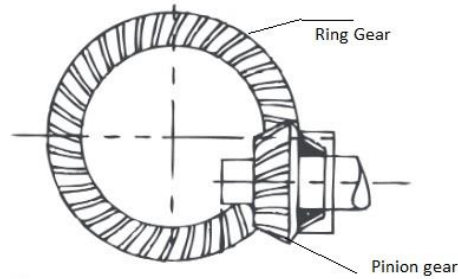

### Ring gear and pinion gear

#### Function:

The function of differential is to make drive wheels of a vehicle rotate at different speeds whenever necessary. Different speeds of drive wheels are required while turning the vehicle.

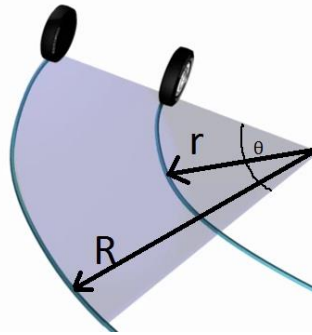

In the above figure the distance moved by inner wheel =  $r\theta$  and the distance moved by outer wheel =  $R\theta$

It's evident from the figure that the  $R > r$ . So the outer wheel travels more distance than the inner one. Again both the wheels have to travel corresponding distances in same time. So to turn the vehicle without skidding in above case the outer wheel has to move faster than the inner wheel. This requirement of drive wheels is accomplished by employing differential mechanism.

#### Working principle:

First the power is transferred from propeller shaft to pinion gear. Pinion gear transfers power to the ring gear. As the spider gear is connected with the ring gear, the spider gear rotates along with it. Finally from the spider gear, power gets transferred to both the side gears.

–When the vehicle moves straight, the spider gear doesn't spin & will make BOTH the side gears rotate at same speed.

–When the vehicle moves on a curved road, the spider gear itself spins & either of the side gears move slower or faster than other one. Which will be faster & which will be slower is decided by the turn.

**Conclusion:**

The differential mechanism of automobile was studied successfully.

### Experiment-3

**Aim of the experiment:** To study hydraulic braking system.

**Apparatus required:** Hydraulic braking system model.

#### **Theory:**

A hydraulic braking system transmits brake-pedal force to the wheel brakes through pressurized fluid, converting the fluid pressure into useful work of braking at the wheels. A simple, single-line hydraulic layout used to operate a drum and disc brake system is illustrated in Fig. The brake pedal relays the driver's foot effort to the master-cylinder piston, which compresses the brake fluid. This fluid pressure is equally transmitted throughout the fluid to the front disc-caliper pistons and to the rear wheel-cylinder pistons.

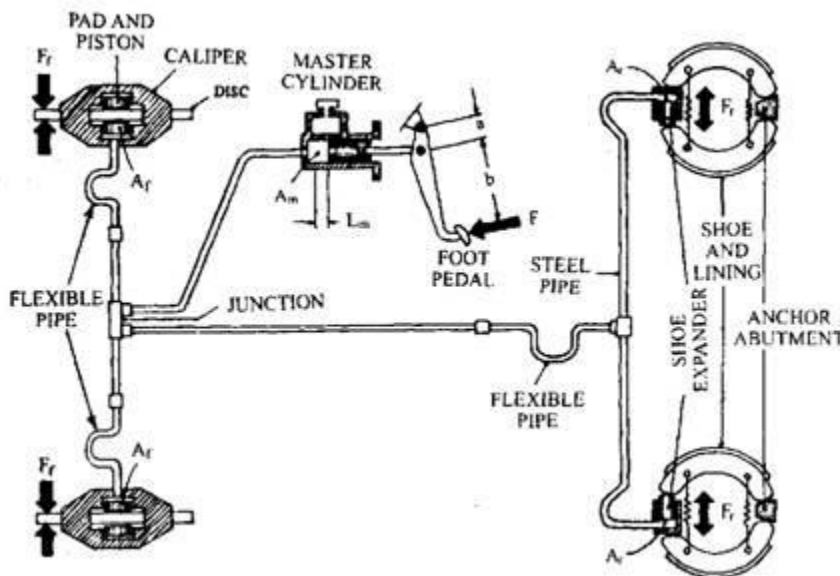

In a hydraulic braking system the braking force is directly proportional to the ratio of the master-cylinder cross-sectional area to the disc or drum-brake wheel-cylinder cross-sectional areas. Therefore these cylinder diameters are appropriately chosen to produce the desired braking effect. The wheel-cylinder cross-sectional areas of the front and rear disc-and drum-brakes respectively may be chosen to produce the best front-to-rear braking ratio. Hydraulic fluid is incompressible provided there is no trapped air in the system. If air is present in



the braking circuit, the foot-brake movement becomes spongy. In a hydraulic system the internal friction exists only between the cylinder pistons and seals. The friction is caused by the fluid pressure squeezing the seal lips against the cylinder walls as the piston moves along its stroke.

The hydraulic system offers the following advantages over the mechanical layout,

- (a) This provides equal braking effort on all wheels.
- (b) This requires relatively less braking effort to deliver the same output.
- (c) This is a fully compensated system so that each brake receives its full share of the pedal effort.
- (d) The efficiency of the hydraulic system is greater than that of the mechanical layout.
- (e) This system is suitable for vehicles having independent suspension.
- (i) It is easy to alter thrust on shoe because the force exerted on a piston depends on the piston area. The larger the area, the greater the thrust on the trailing shoe, so a larger piston can be used.

### **Components of hydraulic brake:**

#### **Brake pipes:**

These are steel pipes which form part of the fluid circuit between the master-cylinder and the wheel-cylinders. These pipes transfer the fluid along the body structure and rigid axle members. Flexible hoses connect the sprung body pipes to the unsprung axle wheel-brake units, to allow for movement

#### **Master cylinder:**

This converts foot-pedal force to hydraulic pressure within the fluid system by means of the cylinder and piston.

#### **Disc brake:**

This comprises of a disc bolted to the wheel hub. This is sandwiched between two pistons and friction pads. The friction pads are supported in a caliper fixed to the

stub-axle. When the brakes are applied, the pistons clamp the friction pads against the two side faces to the disc.

Drum brake:

This uses two brake-shoes and linings supported on a back-plate. The back-plate is bolted to the axle-casing. These shoes pivot at one end on anchor pins or abutments attached to the back-plate. The other free ends of the both shoes are forced apart when the brakes are applied. The shoes expand radially against a brake-drum positioned concentrically on the wheel hub.

Wheel cylinder:

As the hydraulic line pressure acts on the cross-sectional area of the disc and drum cylinder pistons in wheel cylinders, the hydraulic pressure is converted into braking effort. This braking effort either presses the friction pads against the side faces of the disc or forces the shoe friction linings against the inside of the drum.

**Conclusion:**

The hydraulic braking system was studied successfully.

**Experiment-4**

**AIM OF THE EXPERIMENT:**

Checking the spark plug, setting the port and check the ignition in the spark plug.

**APPARATUS REQUIRED:**

SL.NO	EQUIPMENTS	SPECIFICATION	QUANTITY
01	Spark plug testing set up		01
02	Condenser		01
03	Distributor		01
04	Battery	12v	01

## **THEORY:-**

It consists of central electrode, earth electrode, ceramic insulator as main parts. It's mounted on the cylinder head with the help of threaded joint. One end is connected to the high voltage power source whereas the other end is inserted into the clearance volume of cylinder.

The plug is connected to the high voltage generated by an ignition coil or magneto. As the electrons flow from the coil, a voltage difference develops between the center electrode and earth electrode. No current can flow because the fuel and air in the gap works as an insulator. But as the voltage rises further, it begins to change the structure of the gases between the electrodes. Once the voltage exceeds the dielectric strength of the gases, the gases become ionized. The ionized gas becomes a conductor and allows electrons to flow across the gap and produces spark. This spark ignites the air-fuel mixture.

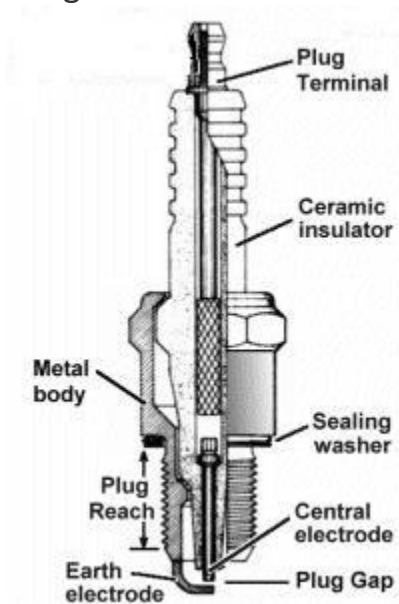

## **PROCEDURE:**

- Set the spark plug on to the cylinder head with the help of a spanner.
- Connect the positive terminal of the battery to the primary winding of ignition coil.
- Connect the primary winding to the contact breaker.
- Connect the secondary winding of ignition coil to the distributor.
- Then switch on the ignition switch.

- The ignition coil steps up 12 volts from the battery to the high tension voltage of about 20,000 to 30,000 volts required to jump the spark at the spark plug gap.
- The rotor of the distributor revolves and distributes the current to the four segments which sends it to the spark plugs.
- Then the spark will be generated in the spark plug.

**CONCLUSION:**

The Spark plug was successfully set and ignition in the spark plug was checked.

## Experiment-5

### **Aim of the experiment:**

To study different circuits of carburetor.

### **Apparatus required:**

Model of carburetor.

### **Theory:**

Carburetor is a device that produces air fuel mixture for internal combustion engine. There are six different circuits of carburetor. The circuits are :

1. Float circuit
2. Idle circuit
3. Main metering circuit.
4. Power circuit
5. Accelerator pump circuit.
6. Choke circuit.

### **Float Circuit**

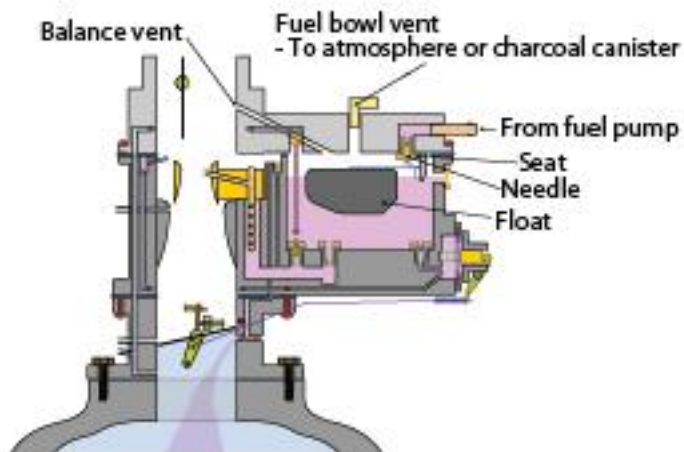

The float chamber holds a quantity of ready-to-use fuel at atmospheric pressure. Its supply is refilled by a float driven valve. As the level drops, the float drops too and opens an inlet, which allows the fuel pump to deliver more fuel to the float chamber. The float rises with the replenished fuel level, closing off the inlet. To allow atmospheric pressure to act on the fuel, the float bowl is open to either the atmosphere (unbalanced carburetor), the air horn above the venturi (balanced carburetor), or the charcoal canister (evaporative emission carburetor). If the float level is too low, more airflow through the venturi will be required to pull out the fuel, leaning out the air–fuel ratio. Consequently, too high of a float level will cause the mixture to be too rich. Float adjustment is important when rebuilding a carburetor. Flooding a carburetor also produces rich mixtures. Flooding can be caused by a worn needle and seat, or by dirt trapped between the needle and seat that causes the level in the float bowl to rise and fuel to dribble from the nozzle, resulting in little or no venturi action.

## Idle Circuits

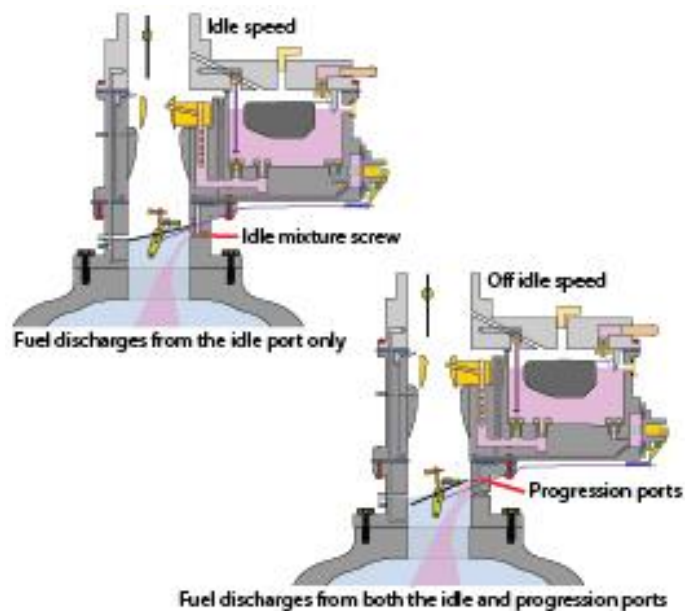

When the throttle valve is closed or nearly closed, the manifold vacuum created behind the throttle is sufficient to pull a small amount of fuel and air through small openings located after the butterfly valve. This design is called the idle

circuit, and it enables the engine to keep running when there is not enough air speed through the venturi to create a vacuum. As the throttle valve opens slightly, the manifold vacuum is reduced, so additional small openings are revealed to compensate for this. This design is the “off-idle” circuit.

## Main Metering Circuit

The main metering circuit comes into action above fast idle, as airflow through the venturi increases. A main metering jet in the float bowl meters fuel passing into the discharge nozzle. How much fuel leaves the nozzle depends on the pressure difference created by the airflow through the venturi. As the throttle opens, and airflow increases and speeds up, more and more fuel is drawn from the discharge nozzle. However, the mass of air does not increase in proportion with the speed, and as a result, high speeds can produce a mixture that is too rich. To correct this, more air can be added. This is called compensation by air correction.

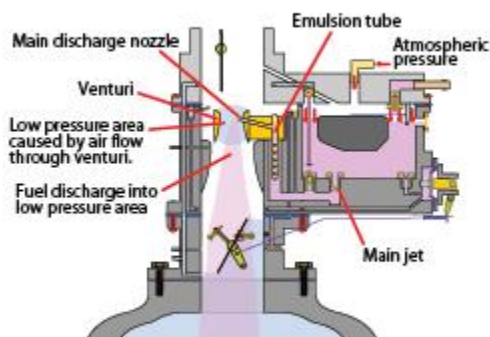

As the throttle opens and engine speed increases, the level in the jet well falls, exposing air bleed holes in the discharge tube. Air can now mix with the fuel and prevent the mixture from becoming too rich. As the throttle opens farther, the fuel level falls too, exposing more air holes. More air bleeds in to maintain the correct mixture. Main metering fuel flow can typically be adjusted by replacing the removable jets with jets having larger or smaller orifices.

## Power Circuit

The size of the main jet is selected to provide the best mixture for economy under cruising conditions. When the throttle is open wide for maximum power, a richer mixture is required. The extra fuel is provided by a power valve, with a vacuum piston and rod opening it as it is needed. At low speeds, intake manifold vacuum is transferred through a passage to the vacuum piston. This holds the piston up and keeps the power valve closed. With the throttle valve fully open for full engine power, the vacuum in the intake manifold falls. A spring pushes down the vacuum piston and rod to open the power valve. Additional fuel flows through the power valve to enter the fuel well and add to the fuel from the main jet. This provides the extra fuel needed to enrich the mixture for full power. Some carburetors use metering rods instead of a vacuum piston. The metering rods are pulled down into the main jets at idle and cruise to restrict the fuel flow. When manifold vacuum drops under heavy load, springs push the metering rod(s) up, increasing the opening size of the main jet(s). Other carburetors use a diaphragm type power valve that opens an additional passage when vacuum drops under load.

## Accelerator Pump Circuit

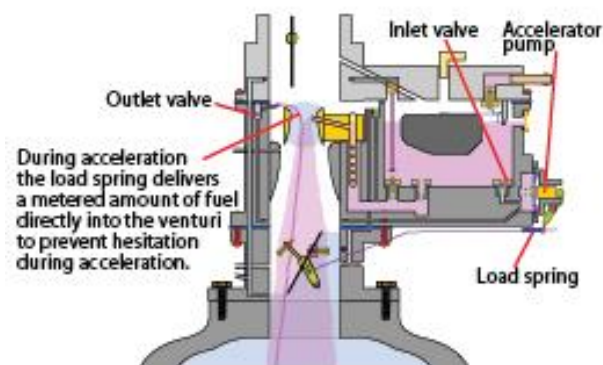

Extra fuel is also needed for accelerating. Suddenly opening the throttle increases the airflow, but fuel cannot flow from the discharge nozzle quickly enough to



match it. An extra squirt of fuel is needed, which is where the accelerator pump circuit comes into play. Depressing the pedal compresses a duration spring that exerts a force on the plunger of a small plunger pump. This pressurizes fuel below the plunger and closes off the inlet valve. Fuel flows past a check valve and enters the airstream from a discharge nozzle above the venturi. The duration spring extends the time for delivering the fuel. Releasing the pedal lets the linkage move the plunger upward. The check valve closes and the inlet valve opens to let fuel refill the pump chamber from the float bowl, priming it for the next shot of fuel. Thus, whenever the throttle is opened, the accelerator pump discharges a small amount of fuel into the throat of the carburetor.

### **The Choke**

Fuel ignites less readily when cold, and if the engine is also cold, then some fuel vapor can condense out of the air–fuel mixture onto the intake manifold and cylinder walls. This loss of air makes the combustible mixture leaner. To compensate for this, a valve known as the choke restricts the flow of air at the entrance to the air horn, lowering the pressure at the venturi and off-idle circuits even though the throttle valve has been opened. In this way, fuel is sucked into the incoming air through all the fuel circuits—idle, off-idle, and main—at the same time.

The choke can be controlled manually by a cable that operates the valve. However, most are controlled automatically so that the valve is closed when the engine is cold and opens progressively as the engine warms up. When the engine is warm, the fuel drawn into the manifold vaporizes readily, and the engine can be started without the aid of a choke. The choke should operate as briefly as possible. Overusing it produces rich mixtures that cause exhaust pollution and increase fuel consumption. Some later-model carburetors that used a cable-operated choke also used a spring-loaded choke release that turned the choke off after a set time.

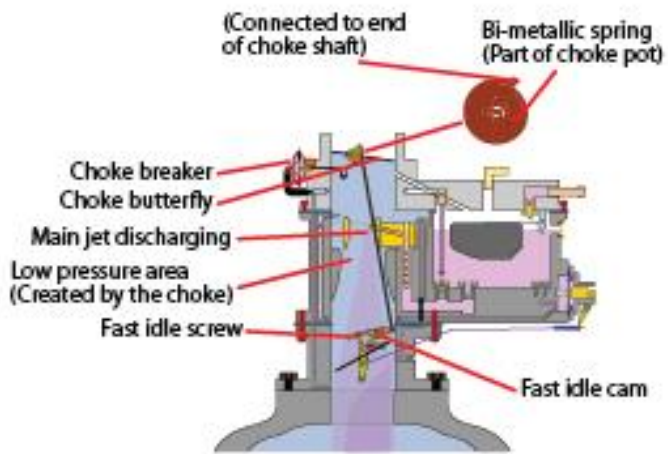

**Conclusion:**

Different circuits of carburetor are successfully studied.