

Horn circuit

Diagram:

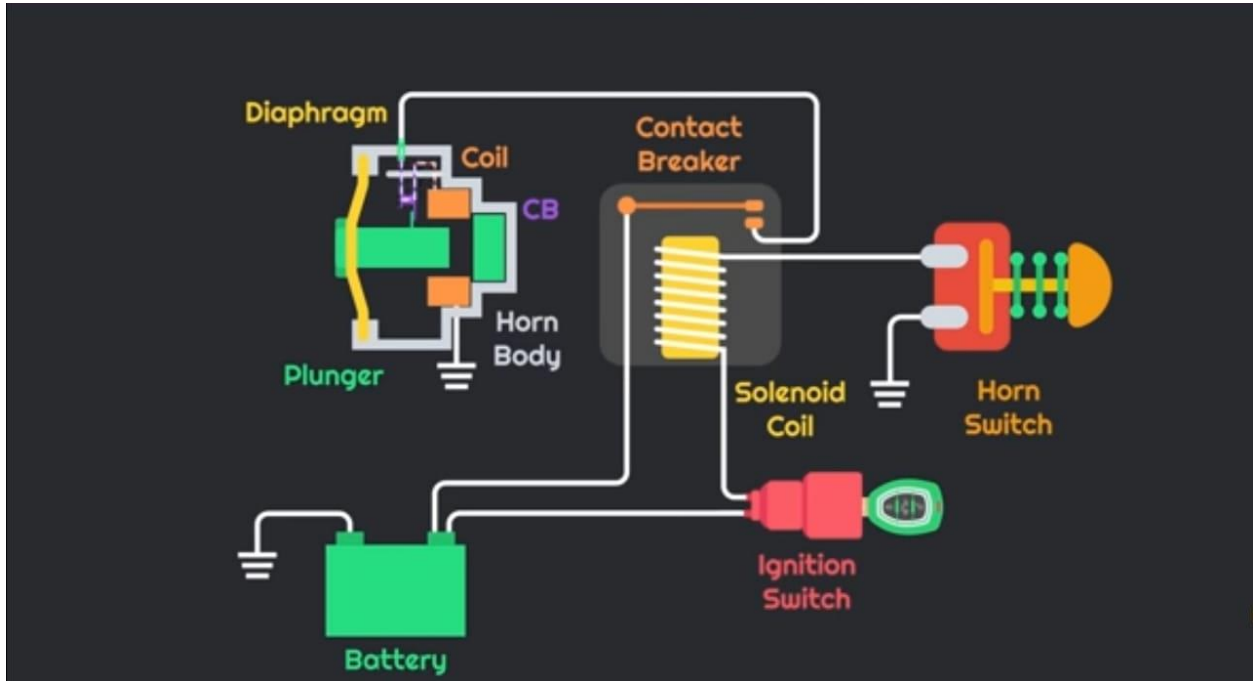

Horn switch is released.

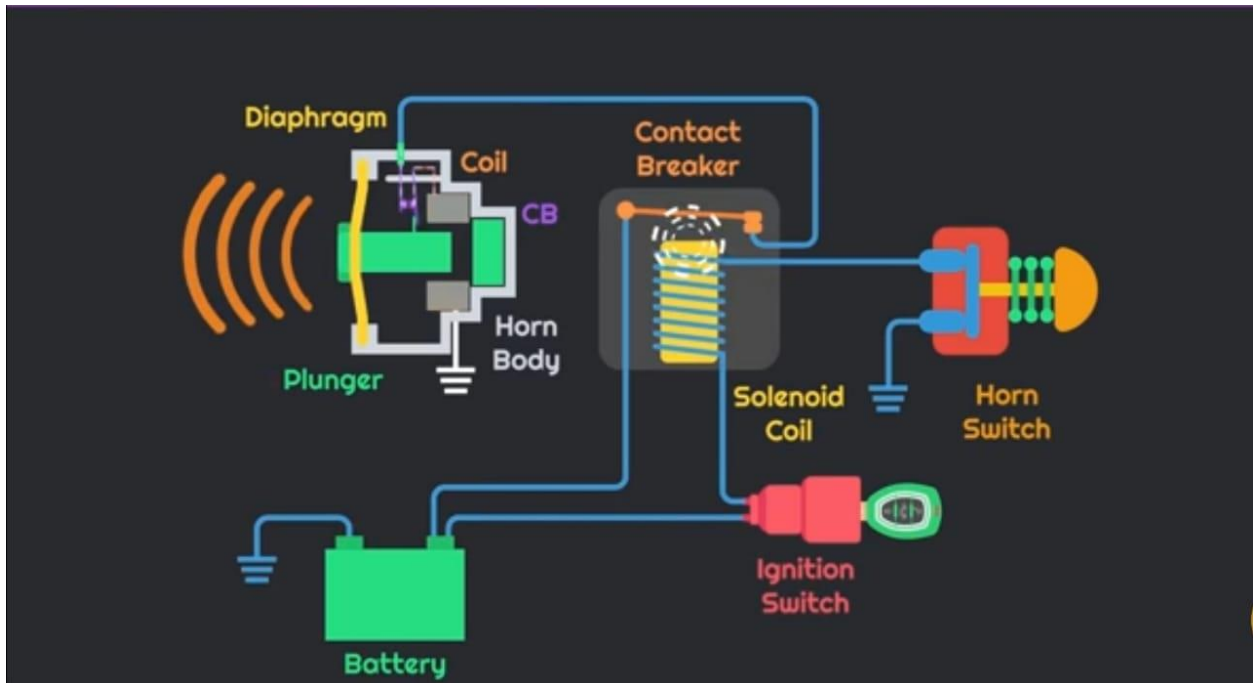

Horn switch is pressed.

Construction and Working principle:

It consists of a battery, solenoid coil with contact breaker, horn switch, horn body etc. There are also a diaphragm, plunger, coil, contact breaker which are housed in horn body. The wiring diagram is shown in the above figure. When ignition is switched off, the path of current from battery to horn switch is open. In that condition the horn can't be blown even if horn switch is pressed. When the ignition is switched on, the path is closed and current flows from battery to horn switch. Consequently, the contact breaker is activated and due to the electromagnetic field of the solenoid coil. Then the current flows from battery to the solenoid coil inside the horn body. This solenoid coil pulls the plunger towards right. While moving towards right, the plunger breaks the path of current to solenoid coil. Consequently, the plunger moves towards left due to the action of diaphragm. This to and fro motion of the plunger occurs at high frequency and cause blow of horn. When the horn switch is released, the flow of current through solenoid coil outside the horn body is stopped and electromagnetic field gets vanished. This deactivates the contact breaker near the solenoid coil and flow of current to the solenoid coil inside the horn body is stopped and as a result, the vibration of plunger is stopped.

Lighting Circuit

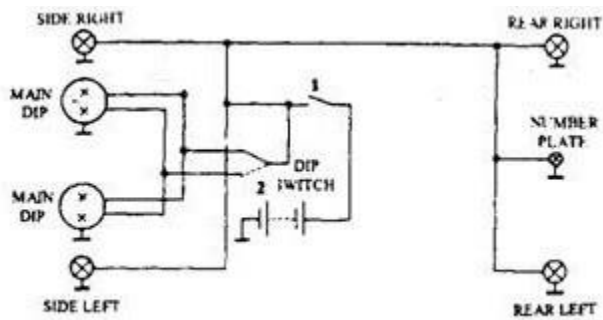

To obtain maximum illumination the lamps are connected in parallel. With the arrangement an open circuit in any branch causes failure only in that one branch, the other lamps still function normally. The vehicle lighting systems normally use an earth return circuit, because this requires less cable length than an insulated return or two wire system. The lamps in this parallel circuit are controlled by two switches. Switch 1 works as the main switch of the circuit and operates the side and rear lights, number plate lamp and head light. Switch 2 distributes the current to either the main beam head lamps or the dip-beam head lamps. One terminal of battery is connected to the metallic body of vehicle and the other terminal is connected to terminals of different lights through suitable switches as shown in figure. Other terminals of the lights are connected to the metallic body of the vehicle. Thereby, lighting circuit is completed. When switch 1 is on, the lighting circuit is closed and current flows from the battery to different lighting devices and the devices illuminate. Switch 2 is operated to change the flow of current from main lamp to dip dip lamp. When switch 1 is in off position, flow of current in the circuit is stopped and all the devices gets switched off.

Spark Plug

Purpose:-

Spark plug is an electrical device that is used for igniting compressed air fuel mixture by means of an electric spark.

Construction and working principle:-

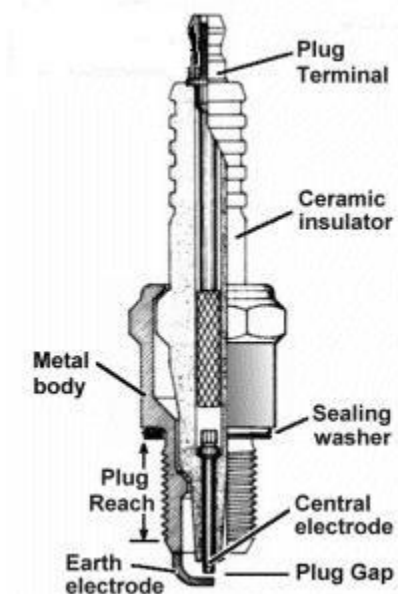

It consists of central electrode, earth electrode, ceramic insulator as main parts. It's mounted on the cylinder head with the help of threaded joint. One end is connected to the high voltage power source whereas the other end is inserted into the clearance volume of cylinder.

The plug is connected to the high voltage generated by an ignition coil or magneto. As the electrons flow from the coil, a voltage difference develops between the center electrode and earth electrode. No current can flow because the fuel and air in the gap works as an insulator. But as the voltage rises further, it begins to change the structure of the gases between the electrodes. Once the voltage exceeds the dielectric strength of the gases, the gases become ionized. The ionized gas becomes a conductor and allows electrons to flow across the gap and produces spark. This spark ignites the air-fuel mixture.